

SONAR WALKING STICK

BY CORNELIO FURLAN AND VIVIAN SU

Senior project

Advisor: Tina Smilkstein

ELECTRICAL ENGINEERING DEPARTMENT

California Polytechnic University

San Luis Obispo

2014

Abstract:

The ability to aid the visually impaired is a field that has the potential to advance itself with the improvement of technology. Many of these products that assist those in need can cost up to \$650, which is an expense that not everybody in need can afford. This means that the technology doesn't get into the hands of all those who need the devices. The sonar walking stick designed in this report, offers a cheaper solution, with a price of under \$200, to assist those who need it with the use of the Arduino Mini Pro. The Arduino processes information received from an ultrasonic sensor and outputs object's locations to the user through vibrational motors. This cane will detect objects that are found in the average person's visual focal area and alert the user of their location.

Contents

Abstract:.....	2
Table of Figures	4
Chapter 1: Introduction	5
Chapter 2: DESIGN PLANNING.....	6
Chapter 3: CODING	9
Chapter 4: BUILDNG AND TESTING.....	11
Chapter 5: Conclusion.....	17
REFERENCES	18
APPENDIX A: ABET ANALYSIS.....	19

Table of Figures

Figure 1: Top View of Detection Area	6
Figure 2: Level 1 Block Diagram	7
Figure 4: Block Diagram of Design.....	10
Figure 5: Sensor Output with Object Detected at 1 Foot.....	11
Figure 6: Sensor Output with Object Detected at 3 Feet	12
Figure 7: Vibration Motor Input, Object Detected at 1 Foot	13
Figure 8: Vibration Motor Input, Object Detected at 3 Feet.....	13
Figure 9: Sensor Configuration (Top View).....	14
Figure 10: Picture of Arduino Mini, Motors, and Sensors Integrated Together	15
Figure 11: Side View (left) and Front View (right) of Final Product	16
Figure 11: Gantt Chart	20
Figure 12: Sales Model	21

Chapter 1: Introduction

The idea of this project comes from a zoologist at the University of Leeds, UK. He got his inspiration by watching bats find food. Bats emit ultrasonic chirps that bounce back off their mosquito prey. Bats work out the distance to dinner by timing the echo's return - a long delay means food is far away. "They echo locate, like submarines," he says.

The goal of this project is to create a lightweight device that uses the concept of bat echoes to enhance the quality of life for persons with a visual impairment. The device emits sound waves and picks up the reflections of these waves to map obstacles in the users surrounding. Throughout an average day a typical person will encounter many obstacles. Some typical obstacles encountered might include: hanging signs, tree branches, light poles, fire hydrants, people, curbs, furniture and stairs.

A typical walking stick is used by moving the stick from one side to side and detecting objects through feel. The sonar walking stick will improve on this by adding an additional mode of detection not possible with the typical walking stick. A typical walking stick cannot detect objects that are raised off the ground, while the sonar walking stick will be able to detect these objects. The sonar walking stick also does not require constant movement of the walking stick from the user.

The following report will take you through the design planning, building, testing, and future possibilities with this technology. The design planning stage went through multiple steps, including; hardware selection and layout configuration. These steps were repeated until both the selected hardware and layout allowed for the specifications to be met. The building process will go into greater detail on how the code was composed and the piecing together of different components and circuits. The testing process involved collecting data of actual users navigating an obstacle course with both a typical walking stick and the sonar walking stick designed.

Chapter 2: DESIGN PLANNING

The first step in the design process was to determine the range that the sonar walking stick detection. The area determined is shown in Figure 1, as the yellow shaded area, which gives about a 35° clearance and extends approximately 10 feet.

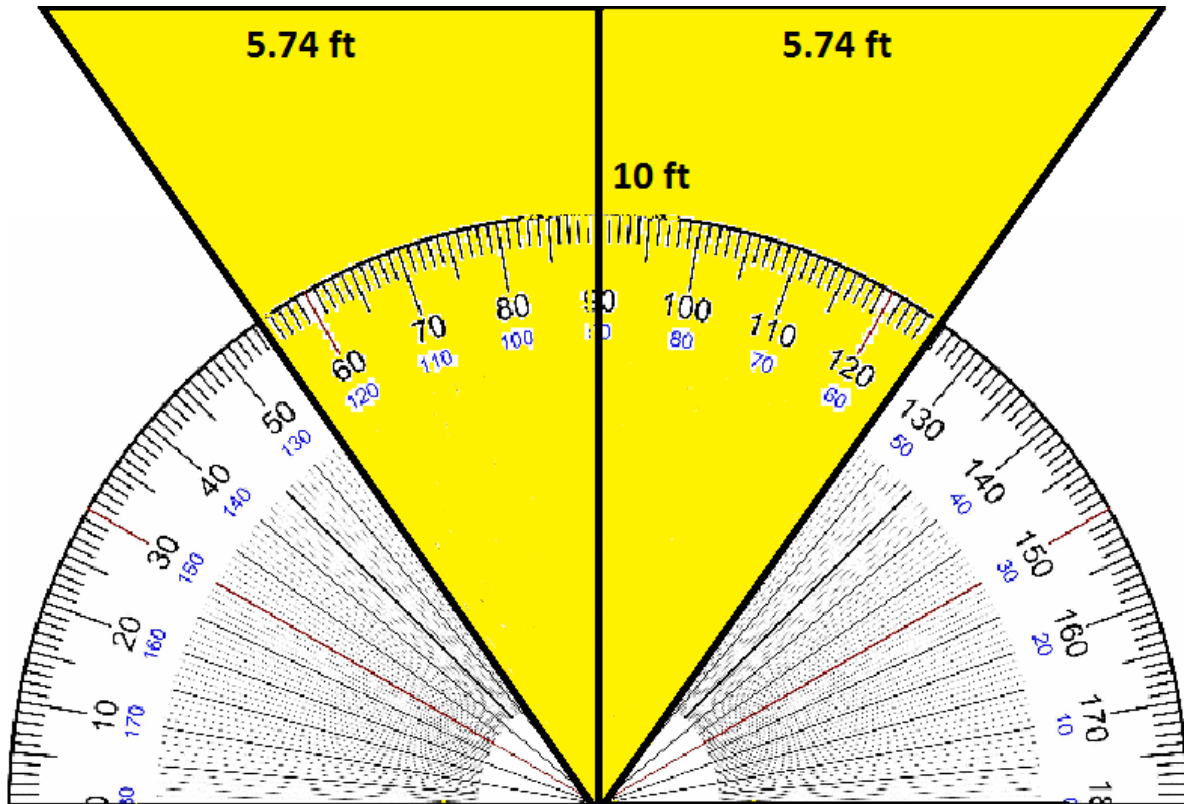

Figure 1: Top View of Detection Area

The angle of 35° was determined to model the visual focus area of a person with good eyesight. The range of 10 feet allows for the detection of faraway objects in a timely manner, so that the user has time to process the information and react. Another benefit to selecting this set of range values, is that it allows for a very accurate detection of objects that are close up.

A Level 1 Block Diagram of the System can be found in Figure 2. There will be two sensors and two vibrating pads that will correspond. Along with this will be the Microprocessor to be the brains of this system.

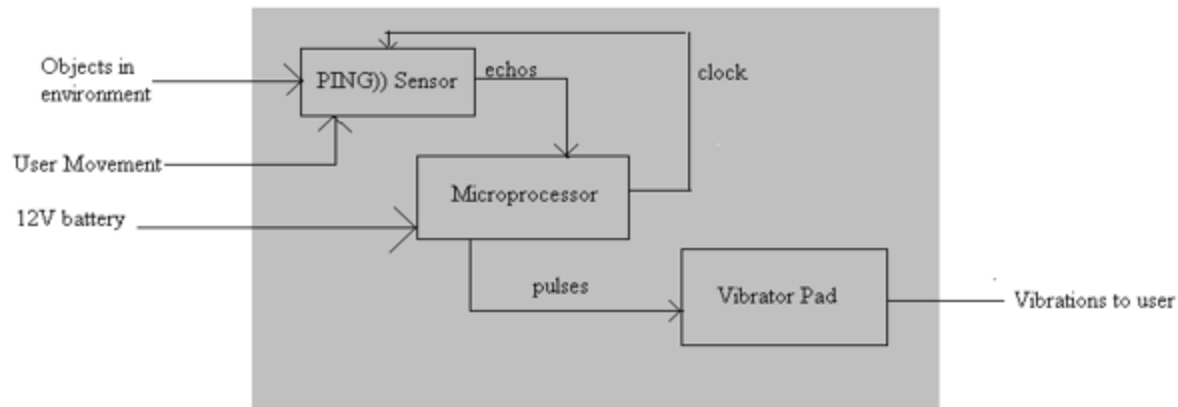

Figure 2: Level 1 Block Diagram

The next step in the design process was to determine the types of sensors and parts that would meet the specifications stated. The types of sensors considered included sonar, infrared, radar, and laser. The radar sensor idea was the first to be thrown out because of its high cost. One of the most important objectives of our project was to provide a low cost alternative to the assisted devices that are already in the market for the visually impaired. Next, infrared sensors were considered as a viable option to meet the project goals. With further research, infrared sensors provided greater accuracy at further distances. However, the project specifications state that the maximum distance the stick needed to detect was closer to 10 feet. It did not seem necessary to provide greater precision for distances that will not be used in this project. The average person can cover 10 ft in about four steps, this allows for sufficient time for the user to avoid obstacles. Also, a flaw of infrared sensors is that they cover a much more narrow range than that needed of the specifications. Ultimately, the sonar sensor seemed to best fit the project. At a low cost, sonar sensors provided a wide range of distances that meet the specifications.

After determining the type of sensors, the next step was to determine how the device would alert the user the proximity of objects. First, audio signals were considered. An audio signal would provide the user with a clear and precise warning of the proximity of objects. However, an audio signal would be difficult to hear in a loud area and cause confusion to the user. Audio signals would also be a distraction to people around the user and annoying to the user. A good alternative to audio signals would be a vibrating interface. Although the device wouldn't be able to distinctly say, for example, "There is an object 2 feet away to the right," it would be a signal that the user can detect, no matter how loud his or her environment is. The vibrational interface would indicate to the user the proximity of an object with different vibrational intensities and speeds. In addition to being a much more discrete way to notify the user, it is also much more cost effective.

Both the sensors and the vibrational interface would be controlled through a microcontroller. One of the biggest microcontroller names in the current market is the Arduino

family, with over 20 different board models. To meet the design spec of being lightweight and portable, the Arduino Mini Pro was chosen. This model is small and lightweight, while still operating at a frequency of 16MHz to provide timely feedback to the user.

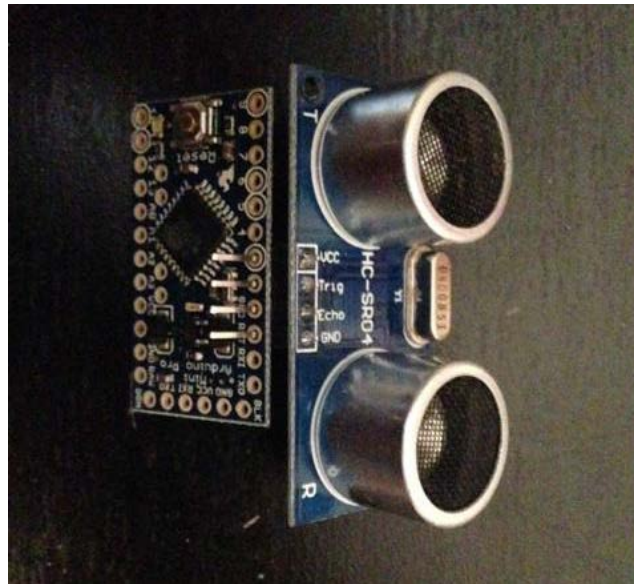

Figure 3: Picture of Ultrasonic Sensor (Right) and Arduino Mini (Left)

Once the types of sensors and notification system was decided, research was conducted to determine which products on the market would make the device most successful. Sensors and their specifications sheets were examined side by side and many were eliminated due to power consumption. With the goal of being a lightweight and portable device, a small battery and small microcontroller must be used. Through much research and consideration, SainSmart HC-SR04 sensors seemed to provide the best accuracy and power consumption and a reasonable cost. However, after ordering and testing, the sensors did not perform according to its specifications sheet. The alternative, Parallax PING)) Sensors were used as a result. Although the Parallax sensors were slightly more expensive, it provided much more accurate feedback and had a range that was closer to the design specifications. A picture of the actual ultrasonic sensor and Arduino Mini is seen in Figure 3.

Chapter 3: CODING

The coding for this build was completed in the Arduino sketch language. This language was chosen because of its simplicity and pre-existing functions. Many of the functions that are already written in the Arduino language allow for the sensors and motors to be easily communicated with. These functions perform almost all the necessary calculations, without having to write complicated functions to perform the necessary tasks. Another benefit of the Arduino sketch language is that it allows for the user to easily change settings on their device. The user benefits from a lot of open-source code and easy manipulation of the default settings. If the user wants to change the range that the sensors detect it is very simple and can be changed by the average person with access to the internet.

The initial step that the code had to do is a small set of setup instructions, which properly boot the microcontroller and label the pins as either inputs or outputs depending on necessity. After the setup the main function begins. The ultrasonic sensors require an input pulse to start functioning. The code initially sends out a pulse to the sensor then sets the same pin to receive the output of the sensor.

A block diagram of the system being coded can be found in Figure 4. The pins on the Arduino that perform pulse width modulation are labeled with a PWM and PWM pins 9 and 10 are used to power the vibration motors. The GND for all the different blocks is common and the 5 V rail is supplied to the Arduino and then to both the sensors. In the block diagram below VM stands for vibration motor and the sensor motor pairs are labeled with the same number. I.e. vibration motor 1 receives data from sensor 1.

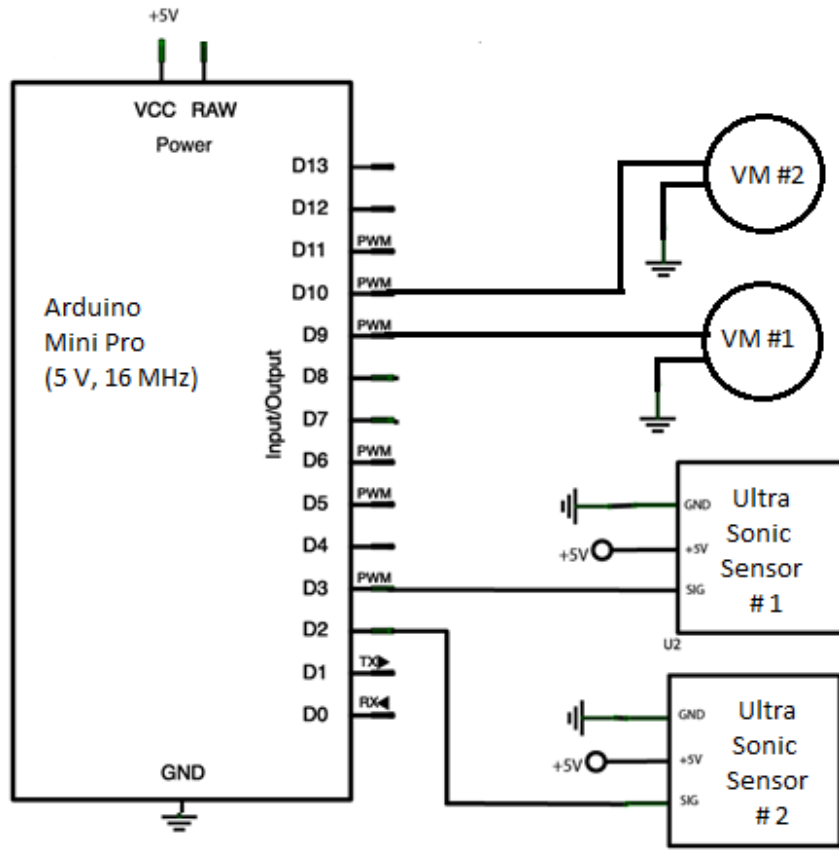

Figure 3: Block Diagram of Design

Once the microcontroller receives the data from the ultrasonic sensor it then processes the data, by measuring the time in microseconds and converting it over to inches. This conversion is used to shrink the range of values that can be sent to the microcontroller from the ultrasonic sensor. This converted value is then mapped to a set of values between 50 and 200, which can then be output to the vibration pad. The pulse width modulated output to the vibration pad sends values from 0 to 255, corresponding from always off and always on respectively. It was found that this value range of 50-200, allow for a good range of different vibration intensities.

There is a similar procedure for the second set of sensor and motor combination. The program goes through a loop to ensure that only one sensor is on at a time to avoid interference. Once again the data is manipulated in a similar manner and output to the vibrator motor.

Chapter 4: BUILDING AND TESTING

After determining that the ultrasonic sensor returns a pulse, whose duration changes depending on the distance of the detected object a plan could be implemented on how to properly relay the information to the microcontroller to interpret it. This was found to be done with the use of an Arduino sketch function called `pulseIn`, which measures the duration of an input pulse in microseconds.

The next step was to integrate one of the ultrasonic sensors to the Arduino and collect data. The data collected is shown figures 5 and 6 with an object detected at 1 foot and another object detected at 3 feet. (These distances are chosen because they allow for the cleanest, most consistent data). What is being observed is the length of time that each pulse is high. The longer the period is high the further the object is away. The object's distance is found from this time interval. The time in microseconds can be converted to inches with the knowledge that sound travels at 1130 feet/second or 73.74 microseconds/inch. For the object at 1 foot (12 inches), in Figure 5, the average time high of 1645 microseconds correlates to 11.2 inches, which is within an expected range. Similarly for the object at 3 feet (36 inches), in Figure 6, the average time high of 5230 microseconds correlates to 35.5 inches, which once again falls into an expected range.

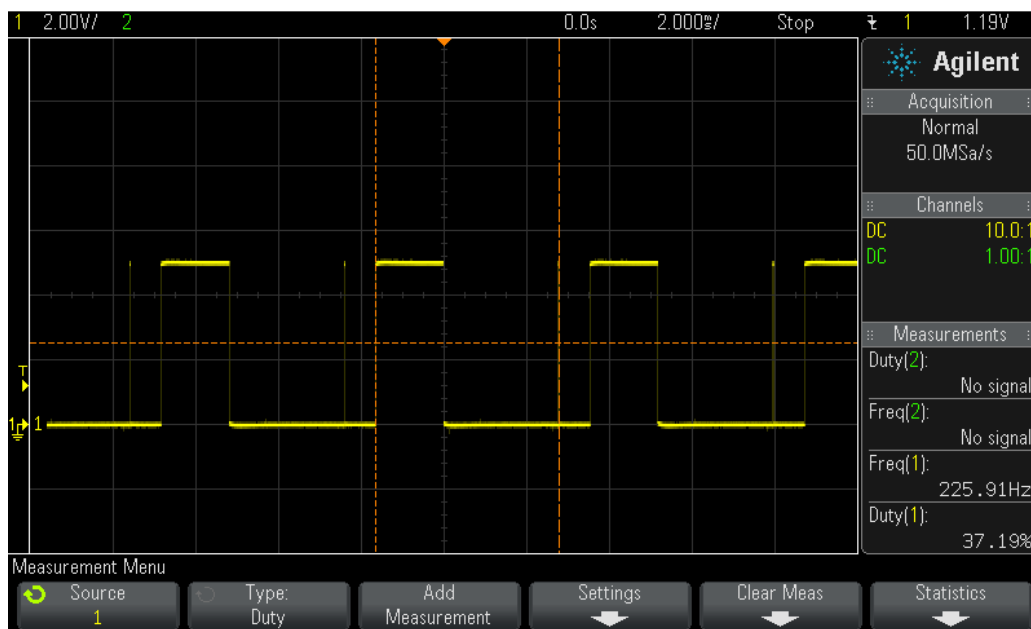

Figure 4: Sensor Output with Object Detected at 1 Foot

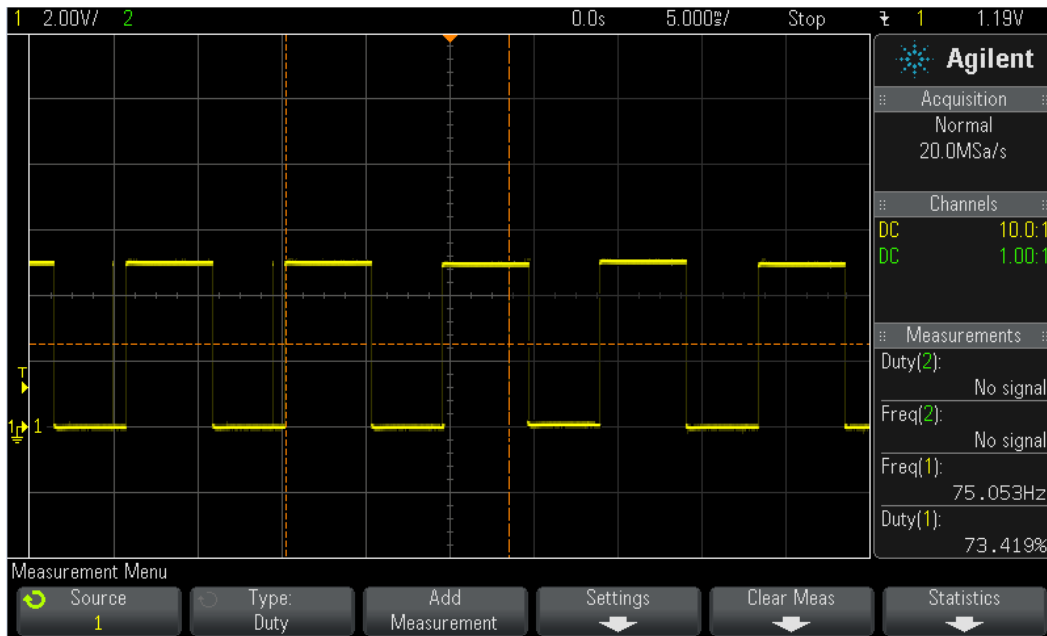

Figure 5: Sensor Output with Object Detected at 3 Feet

Once it was determined that a single sensor was functioning correctly, the next step was to output the information to the vibration motor that would correspond to the sensor. Each sensor has a vibration motor corresponding to it to tell the user distance of objects to the right and left of them, whether on the ground or not. The information is sent to the vibration motor as a pulse width modulated square wave depending on the object's distance. The closer the object, the higher the duty cycle, allowing the vibration to feel more intense.

The collected data can be found in Figures 7 and 8 for the input to the vibration motor. The collected data once again relates to objects detected at 1 foot and 3 feet. The duty cycle in these cases are expected to have values of 72.7% and 60.2% at 1 foot and 3 feet respectively. The closer object has a higher duty cycle allowing a more intense vibration with a close up object.

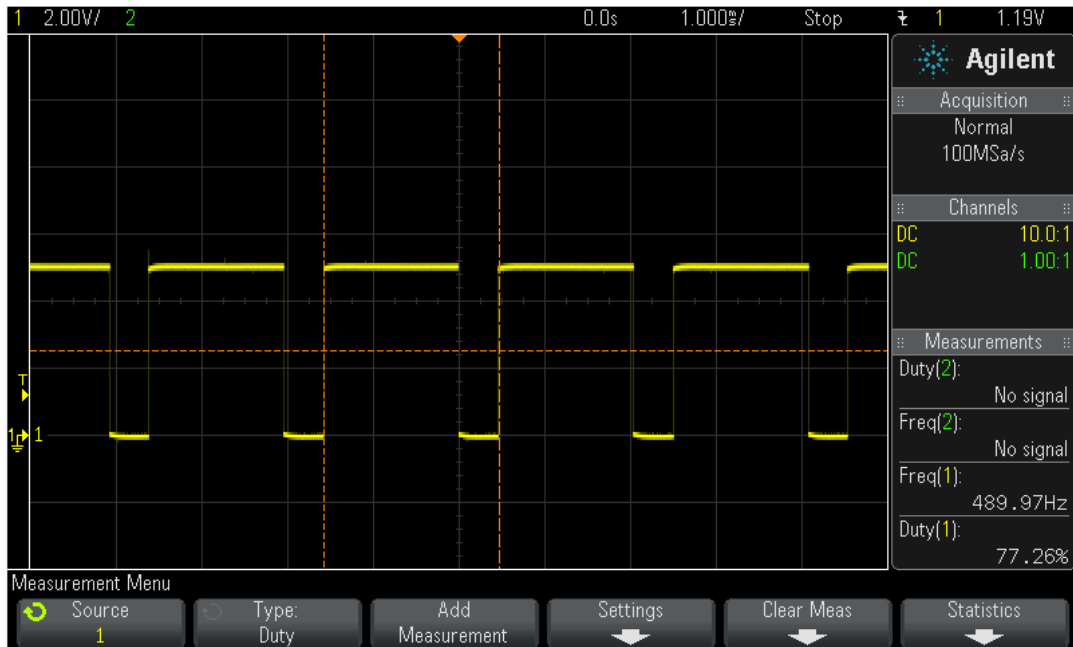

Figure 6: Vibration Motor Input, Object Detected at 1 Foot

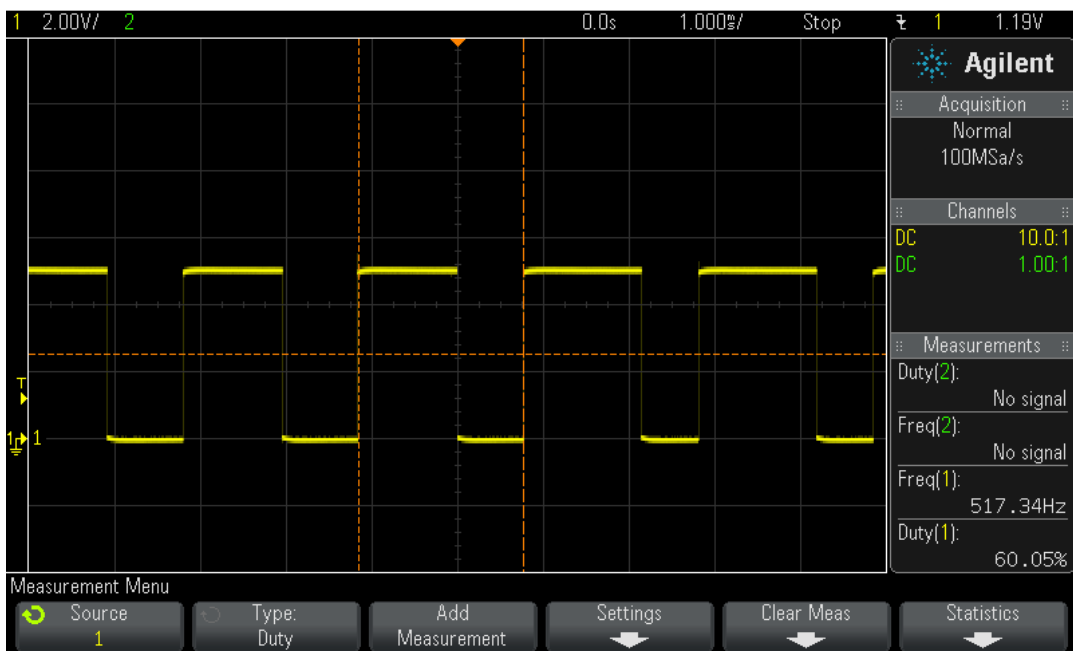

Figure 7: Vibration Motor Input, Object Detected at 3 Feet

After a single vibration motor and ultrasonic sensor were incorporated into the Arduino and functioning as desired, the next step would be to integrate the second sensor and vibration motor. The difficulty with this step is to assure that the sensors do not interfere with each other. This is done with the use of delays and ensuring the sensors were positioned properly as to not set each other off by positioning one in front of the other. The testing for the second set of sensor

and motor was tested and got similar results as to those previously discussed. After knowing the sensors and motors were working properly electronically, a lot of the testing at this point involved feeling the vibration levels and using opinion to determine whether they were too sensitive or just right. The configuration of the two sensors is shown below in Figure 9 below.

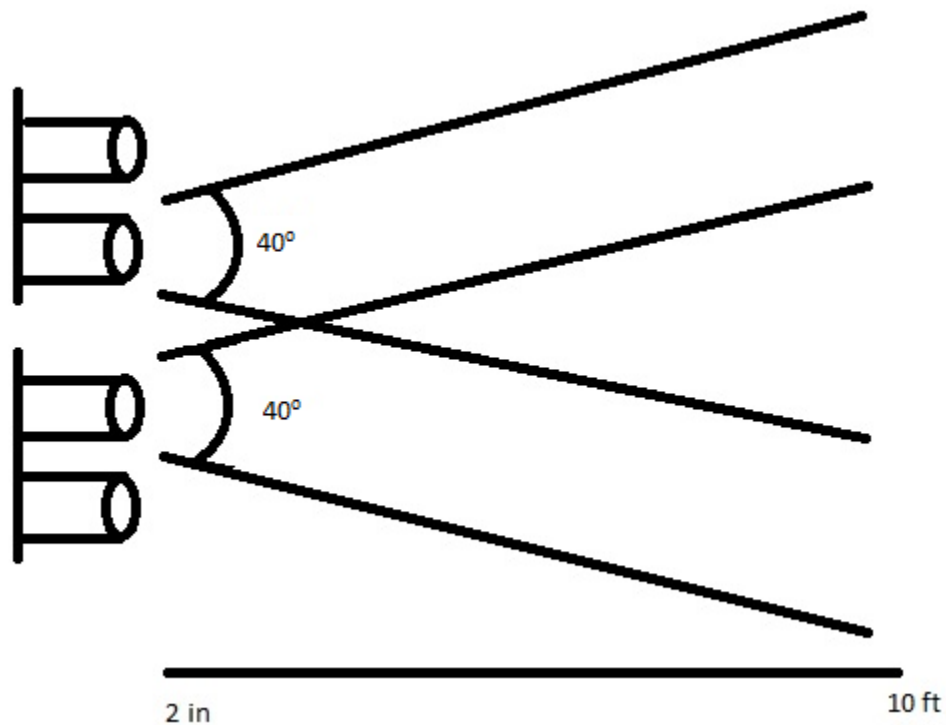

Figure 8: Sensor Configuration (Top View)

The physical view of the block diagram shown in Figure 4 can be found in Figure 10. The picture below shows the project before being mounted on the stick. The breadboard is used to allow for a common ground and common rail for all the devices.

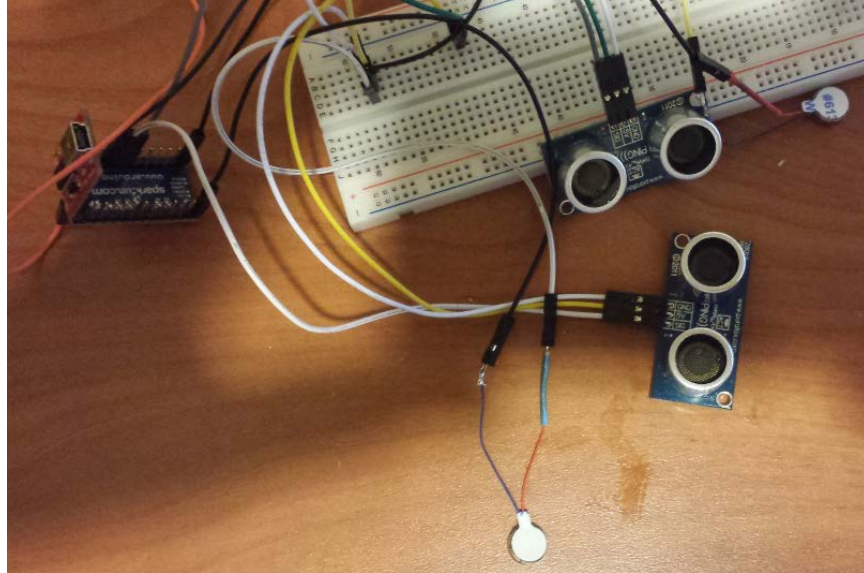

Figure 9: Picture of Arduino Mini, Motors, and Sensors Integrated Together

After determining the project was functioning properly it was then mounted onto the stick to be used as desired. This process involved ensuring that the sensors would remain parallel and above the ground enough as to not allow for the sensors to constantly detect the ground. Another important aspect of mounting the design to the stick is the placement of the vibration motors. They need to be placed in a small area where the user's hand would be placed, but also far enough apart to allow for the motors to operate independently and allow the user to determine which motor is vibrating. When attaching the design to the stick it must also remain light weight as to not allow the final product to be too heavy for use. Pictures of the design mounted to the stick as the final product can be found in Figure 11 which shows the front and side view.

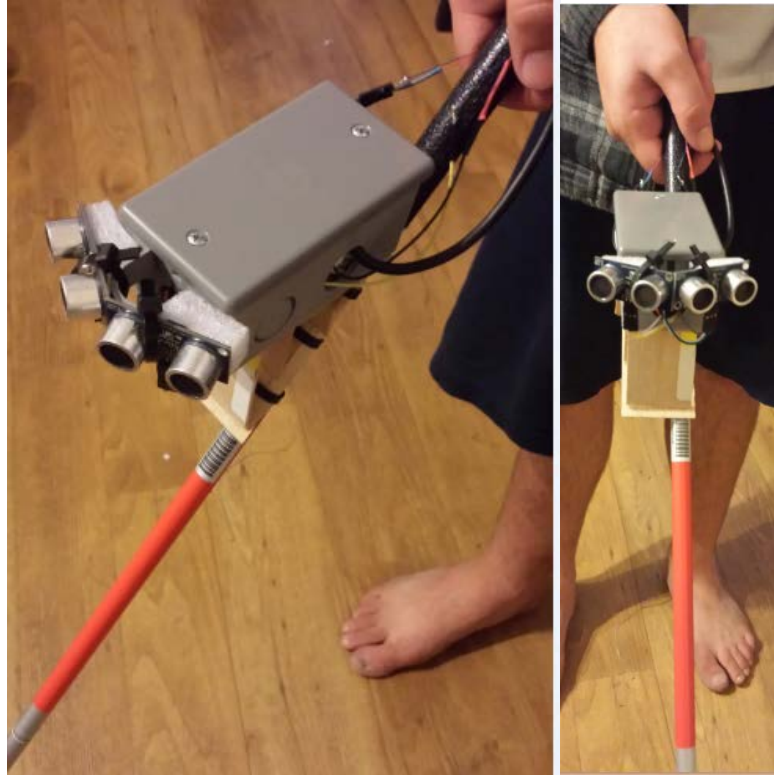

Figure 10: Side View (left) and Front View (right) of Final Product

As seen in the final product pictures the circuitry is contained inside of a small plastic box with the sensors and vibration motors leading outside of the box through holes. The box is then supported with a small stand made of lightweight balsa wood and attached to the stick. This setup allows for the circuitry to be protected while still allowing the peripherals to function properly. The lightweight stand is necessary to allow for the sensors to lay parallel to the ground as to not let it interfere.

The final walking stick ended up weighing 2.5 lbs, well under the design goal of 5. The product was tested with servo motors and the vibration motors attached. With the Servo motors attached the walking stick was able to accurately detect objects out to 9.5 ft and as high as 6 ft. When attaching the vibration motors the varying vibration levels were hard to feel and the cane was accurately able to detect objects out to 7 ft and as high as 5.5 ft. The testing of the cane is still ongoing as accuracy is built upon.

Chapter 5: Conclusion

The goal of this project was to create a lightweight, portable, and affordable device to assist the visually impaired in their daily lives. Currently, other assistive devices or methods in the market are out of reach for many because of its high cost. These include seeing-eye dogs, laser glasses, and other ultrasonic walking sticks, all of which are more expensive than the designed product. These other methods of assistance can cost as much as \$50,000 for a seeing-eye dog, \$2,000 for laser glasses, and \$650 for other ultrasonic sticks, which are 100, 40, and 13 times more expensive than the designed stick respectively.

The end product of project is one that meets all of these goals. However, there are still some considerable adjustments that can be made. With more time and resources, we would like to create a custom holster for the parts with a 3D printer. This will make the product even more compact and would make the system more stable when mounted onto the walking stick. Another improvement that could be made is weather proofing the device to allow the user to be able to utilize the stick in all conditions.

The tests however showed how realistic of a project this is, which a servo motor the cane detected objects accurately up to 9.5 ft away and 6 ft tall. This is within a half foot of the desired. However, with the vibration motors attached the accuracy fell, due to the lack of ability to perceive the different vibration intensities. The cane was only able to detect objects out to 7 ft and 5.5 ft high. Both of these are under the desired range, but are a good starting point to continue improvements.

Also, with more time and resources, we would like to take the test product out into a community to receive more feedback to further develop the product. Although every goal was not met, as students we have learned a lot about sonar-sensing, programming in Arduino sketch, vibration motors, and project management. This is a functioning project that can be continued to be improved over time and with advancement in technology.

REFERENCES

- [1] "Arduino Datsheet." ATMEL, Oct. 09. Web. 21 Oct. 2013.
- [2] "Bats Aren't Blind as Bats." *Science News*, 91.1 (1967): 25.
- [3] Blahut, Richard E., Willard Miller, Calvin H. Wilcox, and F. Alberto. Grünbaum. *Radar and Sonar*. New York: Springer-Verlag, 1991. Print.
- [4]Ishihara, Shinji, Takanori Sato, and Inouchi Mitsuhiro. Sonar. Furuno Electric Company Limited, assignee. Patent 7,245,557. 7 July 2007. Print.
- [5] Mahendran.N, . "Multiple Sensor Feeding Supported Building Automation System Using Arduino Platform with Exposure of 802.15.4 Functionalities." *International Journal of Engineering Trends and Technology*, 4.2 (2013): 77-81.
- [6] Naone, E. 2011. Arduino Uno. *Technology Review*. 114, no. 2: 78-79.
- [7] Patel, Kanubhai K., and Sanjay K. Vij. Proc. of Externalizing Virtually Perceived Spatial Cognitive Maps, Montreal, Que. 7-10 April 2008. Print.
- [8] Ramani, N.; Patrick, P.H. "Fish detection and identification using neural networks-some laboratory results", *Oceanic Engineering, IEEE Journal of*, On page(s): 364 - 368 Volume: 17, Issue: 4, Oct 1992
- [9] R. Y. Kanemori and J. E. Ehrenberg "A microcomputer-based echo integration system for fish population assessment", *Proc. Oceans 1978 MTS-IEEE Joint Conf.*, pp.204 -207 1978
- [10] Sip, Kim-Yeung , "Edge detecting apparatus and automatic device with same" , Patent No. 8018793

APPENDIX A: ABET ANALYSIS

Project Title: Sonar Walking Stick

Student Name(s): Cornelio Furlan _____

Vivian Su _____

Advisor: Tina Smilkstein

• 1. Summary of Functional Requirements

The walking stick sends and receives sonar waves. The reflections of these waves help the user navigate around obstacles in their pathway. A vibrator pad on the handle of the walking stick will vibrate with different frequencies and intensity depending on where the object is located relative to the user.

• 2. Primary Constraints

The biggest limiting factor was the budget of \$150 for the project. Currently, products that incorporate some sort of radar to enhance the mobility of the visually impaired are sold at an upwards of \$500. About 25% of the visually impaired population do not have health insurance and most lower class citizens cannot afford a \$500 “luxury item”, when there is a standard \$20 walking stick. The goal of this project was to create an affordable product that enhances the quality of life for the visually impaired.

Along with the costs, another limitation in this project was the radar specifications of the project. Given that the radar and sensor must fit on the handle of the walking stick, it is hard for the parts to meet the specifications of providing a 10' x 3' x 6' clearance. Finding a way to enhance the performance of these parts, or finding a more efficient solution will be another obstacle.

Another constraint that provides difficulty is the battery of the product. The battery must be a rechargeable battery that a visually impaired person can easily recharge. It must also be small enough to fit on the handle of the walking stick along with the microprocessor and sensor components.

• 3. Economic

This project requires 150+ hours of work, in addition to the \$98.02 for the costs of parts. See Table 4 for cost estimates. Initial costs will be paid for by me. Ideally, the project will take about 32 weeks, with its completion in June 2014. See estimated development time in the Gantt chart displayed in Figure 11. After June 2014, the product is anticipated to enter the market. The product is designed to last 20 years, with its only maintenance requirement being that the battery

needs to be replaced. Profits of \$51.98 per product will be accrued when the product is sold for \$150. There will be a return on interest once 25 products are sold.

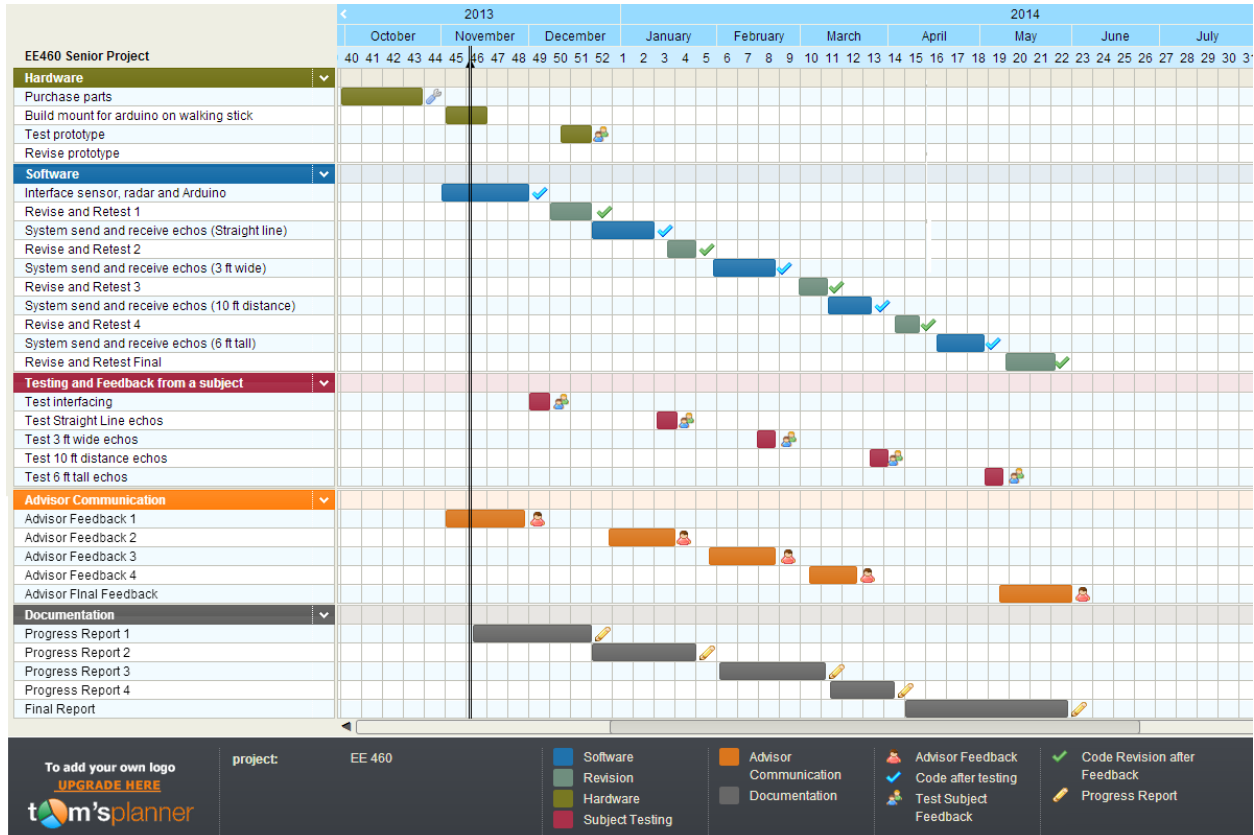

Figure 11: Gantt Chart

Table 1: Cost Estimate

Column1	Column2
Cost Estimates	
Walking Stick	\$32.95
Arduino Pro Mini 328 - 5V/16MHz	\$9.95
Parallax Ping Ultrasonic Distance Sensor	\$29.99
Vibration Motors	\$6.69
Slide Switch	\$2.49
9V Battery (4pk)	\$8.95
Nuts, bolts, wires, and solder	\$8.00
Plastic mount	\$3.00
Total	\$102.02

Labor Estimates

150 hours of labor

\$1200

- **4. If manufactured on a commercial basis**

In the state of California, there are about 704,800 visually impaired citizens. With an estimate that 5% of this population will purchase the product, there will be 70,480 sonar walking sticks sold. Each product will be sold at a price of \$150, which yields a profit of \$43.98 when cost of parts and labor is taken into consideration. According to the Project Sales Forecast Model, 21,144 sonar walking sticks will be sold in the first year, giving a profit of \$73,898.28. See the project sales chart shown below in Figure 12.

Figure 12: Sales Model

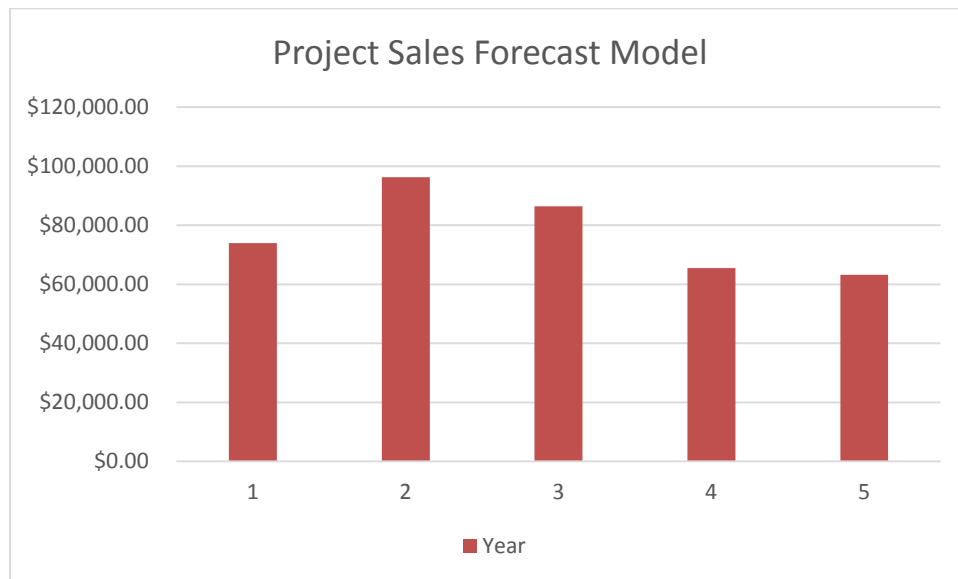

- **5. Environmental**

Natural resources used for this product include silicon, graphite, and heavy metals in the battery. Batteries need to be replaced every 3 years. They contain heavy metals such as mercury, lead, cadmium, and nickel, which can contaminate the environment.

- **6. Manufacturability**

The manufacturability of this product requires loading software into a microprocessor and interfacing the sensor, microprocessor, and feedback system together. The biggest difficulty that could arise is incorrect interfacing of the system or securely mounting the system to the walking stick.

• 7. Sustainability

A large difficulty associated with the maintenance of the walking stick is the battery. Design specifications constrain the battery to be small and rechargeable. Typically, a small rechargeable battery has a lifetime of 500-800 charge/discharge cycles, or around 3 years. Batteries contain heavy metals such as mercury, lead, cadmium, and nickel, which can contaminate the environment. So another goal of the project could be to find a battery that could have a longer lifetime to help with the sustainability of the project.

An upgrade of this project could be that the walking stick provided audio feedback, instead of vibrations, which could more accurately describe the proximity of an object to the user. The issue with this upgrade is that it would require the vibrator pad to be removed and replaced with an audio speaker, which would increase the cost to the user. Another upgrade could be the improvement of accuracy and speed of feedback. This is a much simpler upgrade because it only involves an upgrade in software.

• 8. Ethical

IEEE Code of Ethics: 1. to accept responsibility in making decisions consistent with the safety, health, and welfare of the public, and to disclose promptly factors that might endanger the public or the environment;

Currently, similar products in the market that aide the visually impaired costs an upwards of \$500. It does not make sense to have a product that improves the quality of life be so inaccessible to the masses. About 25% of the visually impaired population do not have health insurance and about 31% live below the poverty line. Studies show that about 47% of people cannot afford the visual aids currently in the market. As engineers, we accept the responsibility of developing products that have the welfare of the public at heart. There needs to be more innovation to lower all cost aspects of this product so that it is more easily accessible.

• 9. Health and Safety

The biggest safety concern is that the product might fail and will not correctly indicate to the user of obstacles. This may cause severe harm to the user. For example, if the vibrator pad was not working correctly, it could misinform the user of the proximity of an object and the user could potentially run into an object and have a head trauma.

• 10. Social and Political

The main stakeholders of this product are the visually impaired population. This project is beneficial to them because it enhances their quality of life. They all should benefit equally because the goal of this project is to be affordable to all classes.

- **11. Development**

For this project, I need to develop a stronger understanding of sonar and signal processing. I also had to understand how to translate signal processing in a microprocessor and output a vibration through a mechanical motor. See attached Literature Search in Appendix A.