

Precast Concrete Manufacturing Business Plan

John Will

California Polytechnic State University, San Luis Obispo, CA

Equipment and Materials



Flatbed Delivery Truck with Boom Attachment

Standard Manhole Base Form

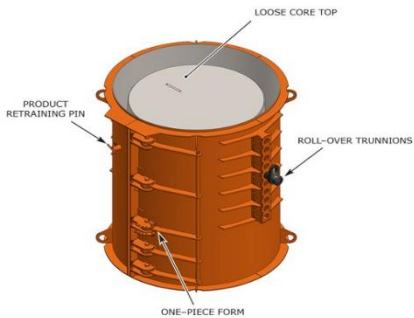

Standard Manhole Baseform

The Central Coast of California has been under continuous development since the Great Recession of 2008. Throughout this development, there has been an exceedingly high demand for precast concrete products, specifically in the Civil sector of the construction industry. This demand has emerged from the lack of concrete product manufacturers in the area. This project introduces a business plan for a new precast concrete product manufacturer by the name of J.W. Concrete Products LLC. The objective of this proposal is to reflect the benefits and potential expansion of a locally owned and operated concrete product business to prospective investors. The plan itself consists of; the structure of the organization, detailed description of the purpose, objectives and goals of the company, the equipment and materials required to begin operations, a detailed description of the costs associated with getting the organization up and running, and lastly an outline of future development and expansion of the business. Introducing a new precast concrete product manufacturer in the Northern Santa Barbara and San Luis Obispo County will introduce a more competitive market and benefit the entire region.

Key Words: Precast Concrete, Business Proposal, Products, Civil, Operations

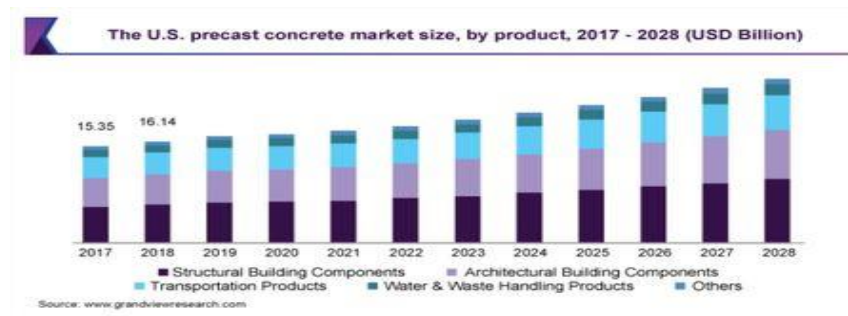

Precast Concrete Market Size Graph

Products

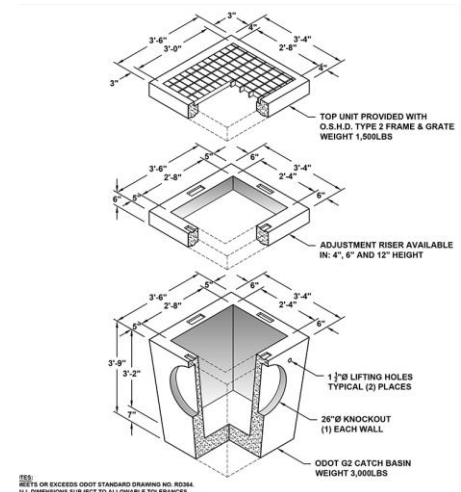

Engineering Design of a Precast Catch Basin



Precast Catch Bains and Drop Inlets