

DESIGN AND IMPLEMENTATION OF AN INSTRUMENTED PEDAL FOR CYCLING BIOMECHANICS RESEARCH

Luke I. Kraemer (1), Juan D. Gutierrez-Franco (1), Jake E. Deschamps (1),
Karim C. Dudum (2), Eshan M. Dandekar (3), Scott J. Hazelwood (1,2),
Hemanth V. Porumamilla (1), Stephen M. Klich (1,2)

(1) Mechanical Engineering Department
California Polytechnic State University
San Luis Obispo, CA

(2) Biomedical Engineering Department
California Polytechnic State University
San Luis Obispo, CA

(3) Kinesiology Department
California Polytechnic State University
San Luis Obispo, CA

INTRODUCTION

Cycling is a common, low-impact activity used for recreation, exercise, and rehabilitation. Knee joint loading can be predicted using inverse dynamic analyses of pedal load cell and kinematic data measured during cycling biomechanics experiments. Several studies have successfully measured foot loading at the pedals, e.g. by using custom instrumented pedal spindles outfitted with strain gauges and a potentiometer to measure crank angle [1-3]. Such designs are relatively complex, requiring difficult machining and component fabrication, and require post-processing of strain gauge data.

The long-term goal of this study is to calculate knee joint loading and, ultimately, cartilage tissue stress to provide evidence-based prescriptions for rehabilitative and fitness sustainment exercises for those who are at high risk for knee osteoarthritis. The objective of this project was to design, fabricate, and implement an instrumented pedal system using existing load cells for use in cycling biomechanics research. Measured data retrieved from the load cells during cycling experiments will be compared to similar studies to verify that this project was successful.

METHODS

Design criteria were specified as follows: 1) to replicate foot motion that occurs with a bicycle's stock pedals, 2) to easily implement the pedals on different bicycles, 3) to incorporate two existing, 6-channel load cells (AMTI AD2.5D-250, Watertown, MA), and 4) to implement with an 8-camera motion capture system (Motion Analysis Corp., Santa Rosa, CA) for tracking motion of the load cell coordinate systems.

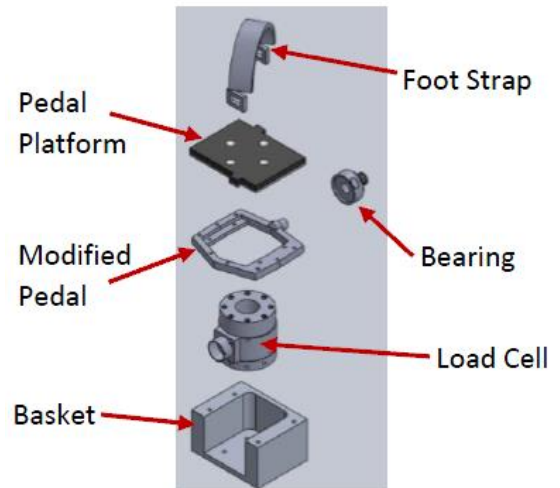

FIGURE 1. EXPLODED VIEW OF INSTRUMENTED PEDAL DESIGN.

Design and fabrication. The design (Fig. 1) replicates the circular foot motion in order to best estimate pedal loading that occurs with a non-instrumented pedal. This was accomplished by lowering the load cell into the body of the pedal. Such a design is difficult to achieve with standard bicycle pedals that have a 2-bearing system with a spindle that extends the entire width of the pedal and, thus, would impede force transmission between the foot and the pedal. Tioga MT-Zero pedals (Tioga, Gardena, CA) were used because their spindle-less design

consequently resulted in ease of implementation with the load cells. The Tioga pedals have a 1-cm long axle that mates with one oversized bearing which threads into the crank. Thus, there is no spindle to interfere with the pedal body where the foot contacts the load cell. Additionally, the Tioga pedals are made from high quality chromoly steel, which is strong enough to allow machining without sacrificing structural integrity. To modify the Tioga pedals, the center skeleton was removed until there was enough room to drop a load cell through the modified pedals (Fig. 1). A custom basket was machined and attached underneath each modified pedal. The load cells were bolted to the baskets and positioned low enough so that the top surface of the load cells followed the standard trajectory of bicycle pedals. The design was finished by fabricating and bolting a pedal platform with a strap (Cybex, Medway, MA) on top of each load cell in an attempt to evenly distribute foot loading and assure secure, continuous contact. The pedal platforms have an aluminum plate for rigidity and a rubber layer to provide friction to enhance contact and to reduce vibrations. In summary, this design required manufacturing two relatively simple components: the pedal platforms and the load cell baskets, as well as minor modifications to the pedals.

Load cells. The existing 6-channel load cells measure forces and moments in three directions and output the data to a data acquisition box without the need of further calculations, filtering, or signal processing of the raw data.

Motion analysis system. Four reflective markers were strategically placed on each pedal (Fig. 2A). During experiments, the 8 digital cameras track marker trajectories and are post-processed to determine crank angle, as well as the origin location and axes directions of the pedal coordinate system (Fig. 2B).

Implementation. To assure that the system is working as desired, cycling experiments were performed at ~ 70 RPM cadence for 3 subjects and pedal loads were compared to published data [1-3]. Inclusion criteria were normal body mass index and no history of leg injuries. Experimental protocols were approved by Cal Poly's Human Subjects Committee and were designed to minimize risk to human subjects.

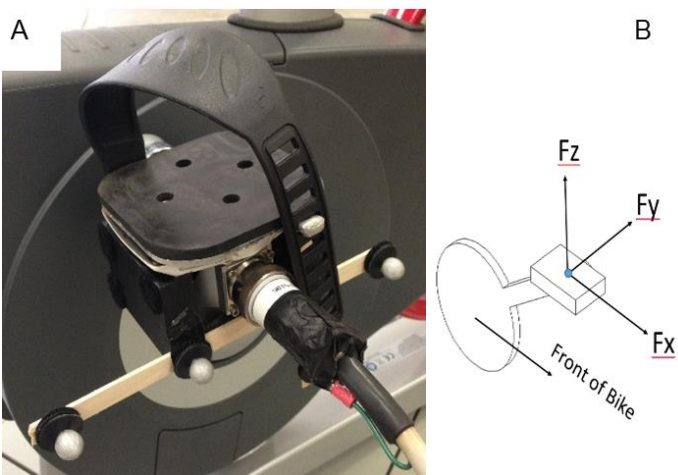

FIGURE 2. A) INSTRUMENTED PEDAL AND MARKER ASSEMBLY MOUNTED ON BICYCLE. B) COORDINATE SYSTEM USED [1].

RESULTS

Cycling experiments using the load cell instrumented pedals yielded force readings as shown below (Fig. 3). These results were compared to previous cycling studies and the range of forces agreed favorably [1-3]. A comparison of the load cell pedal readings to a strain gauge pedal system is shown below (Table 1).

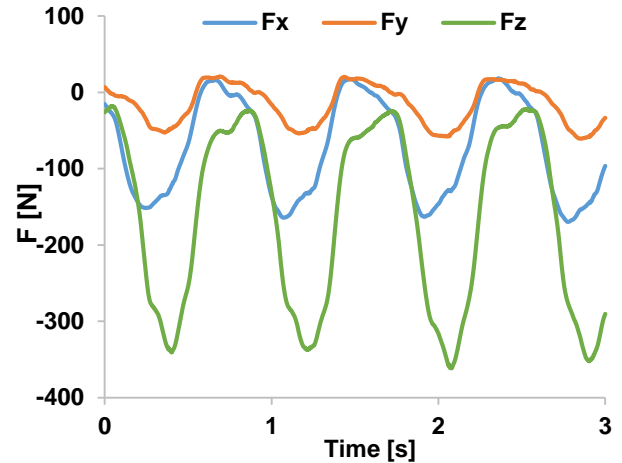

FIGURE 1. MEASURED FORCES ACTING ON THE PEDAL FROM ONE SUBJECT. USING THE COORDINATE SYSTEM SHOWN IN FIG. 2B, THE -X, -Y, AND -Z VALUES CORRESPOND TO FORCE (F) COMPONENTS IN THE POSTERIOR, LATERAL, AND DISTAL DIRECTIONS.

TABLE 1. COMPARISON OF RESULTS OF LOAD CELL INSTRUMENTED PEDAL VERSUS STRAIN GAUGE PEDAL FROM [1].

	Fz Range	Fx Range	Fy Range
Load Cell Pedal	-350N to -10N	-120N to 15N	-70N to 10N
Strain Gauge Pedal	-325N to 0N	-100N to 40N	-75N to 0N

DISCUSSION

The objective to design and fabricate an instrumented pedal for cycling biomechanics research was accomplished using load cells and by modifying a Tioga Mt-Zero Pedal. The finished product was simple, functional, and easily implemented with standard 9/16" bicycle cranks. Experiments were conducted with 3 subjects with a motion analysis system to capture the motion of the load cell origin and coordinate systems. Results for load cell data were consistent with published results using a spindle instrumented with strain gauges. Future aims are to use the instrumented pedal in cycling biomechanics research to estimate knee joint loading in subjects at high risk for knee osteoarthritis, including obese/overweight subjects, transtibial amputee prosthetic users, and ACL deficient and ACL reconstructive surgery patients.

ACKNOWLEDGEMENTS

Funding received from Quartus Engineering Inc. and Cal Poly's Donald E. Bently and STRIDE Centers.

REFERENCES

- [1] Hull, M, Davis, R, *J Biomech*, 14:843-856, 1981.
- [2] Hull, M, Ruby, P, Hawkins, D, *J Biomech*, 25:41-53, 1992.
- [3] Hull, M, Boyd, T, Neptune, R, *J Biomech*, 30:505-511, 1997.