

## **Student industry cooperation for the development of thermal system design teaching laboratory equipment**

**Dr. Steffen Peuker, University of Alaska Anchorage**

Dr. Steffen Peuker is an assistant professor of Mechanical Engineering and the director of the Thermal System Design Laboratory at the University of Alaska Anchorage. He is teaching the Thermal System Design, Thermal System Design Laboratory, HVAC Systems Optimization and Introduction to Engineering courses. His work in engineering education focuses on hands-on undergraduate engineering education in the HVAC&R area, student-industry cooperation, and developing innovative ways of merging engineering fundamentals and engineering in practice and research. Dr. Peuker's educational research also focuses on increasing student retention and success in engineering through a student success focused introduction to engineering course. He is an active member of the American Society of Heating, Refrigerating and Air Conditioning Engineers.

# Student Industry Cooperation for the Development of Thermal System Design Teaching Laboratory Equipment

## Introduction

In higher education, hands-on undergraduate education using state-of-the-art laboratory equipment is important to meet the quality standards expected in the engineering profession. However, the development of modern engineering laboratories is not only time consuming, but also budget constraints can hamper the development of needed laboratories for instructional purposes as Bidana and Billo<sup>1</sup> state:

"Development of state-of-the-art engineering laboratories is becoming an increasing problem in the University environment. Due to the greater variety and increased complexity of much state-of-the-art hardware and software, the cost and cycle time for development and startup of a modern engineering laboratory can be excessive. This, together with decreasing budgets for technician support experienced by many engineering departments, often hamper efforts to develop new laboratories for engineering instruction."

The solution presented by Bidana and Billo<sup>1</sup>, O'Connell et al.<sup>2</sup>, and Webster<sup>3</sup> is to involve students in the designing and building of laboratory equipment. Bidana and Billo<sup>1</sup> investigated the development and startup of an Automatic Data Collection laboratory, whereas O'Connell et al.<sup>2</sup> investigated the development of experiments for a power electronics course. Bidana and Billo<sup>1</sup> concluded that "the use of students for laboratory startup was a win-win situation" and "students were able to gain valuable technical educational skills". O'Connell<sup>2</sup> concluded that "students can participate meaningfully in the course lab component of curriculum development" and Webster<sup>3</sup> argues that "the student's interest is heightened by the design aspects".

Although there is agreement that undergraduate students can be involved successfully in creating laboratory equipment, the question remains if this can be done for the equipment needed for a thermal system design teaching laboratory which requires sophisticated equipment such as an air handling unit simulator, a refrigeration simulator, or an air duct simulator.

This paper presents an innovative approach of cooperation between industry and students to build equipment for a thermal system design teaching laboratory at a four year institution. Instead of buying higher educational laboratory test stands from commercial sources, test stands were built by mechanical engineering undergraduate students—as their senior design project—under the guidance of a faculty member and in collaboration with local industry representatives. The complete process—from initial outreach to the industry to achieve successful buy-in, the cooperative projects management and successful completion of the projects—is described in detail. This process can be replicated at other institutions in order to build educational laboratory equipment in a short time frame—one academic year—and without any funding from the institution.

## **Methods**

So you have a vision or you are being tasked, e.g. as a result of ABET recommendations, to develop a thermal system design teaching laboratory. How should you get started? One way would be to inquire how much funding is available and/or apply for grants and based on the amount available determine what equipment could be bought. But what if there is no funding available from the institution? What if there are no established relationships with the local industry? The next sections of this paper will outline the process taken to answering the previous two questions and show the results, not only of the finished products, but also the educational benefits for the students involved in the projects.

## **Outreach to Industry**

The approach, or process, of developing a thermal system design teaching laboratory within one academic year without institutional funding started with an outreach to local companies associated with heating, ventilation, air conditioning and refrigeration (HVAC&R). In the presented case there was a course in place in the Mechanical Engineering curriculum called Thermal System Design which covers the basics of HVAC&R design; however there was no real cooperation with the local industry in place. Understanding the needs of the local industry is important since they want to hire graduates which are well educated in their field of interest. A good start for a new—but also seasoned professor—is to join and attend meetings of the local professional societies, which in this case was the American Society of Heating, Refrigerating and Air Conditioning Engineers (ASHRAE). This initial step is crucial to get into personal contact with representatives and to start a conversation about the vision one has for developing a HVAC&R related undergraduate teaching laboratory. Just talking about the vision—providing hands-on undergraduate education relevant to the needs of the local companies— resulted in a donation of a 3-ton air handling unit. Another step was to personally visit the local companies and talk to the managers as well as engineers to get a better picture of their needs, current concerns regarding recent graduates they hired, and what they perceive would enhance the education of the students. As a result, hands-on education related to building HVAC&R—including building automation—was one of the highest priorities.

Asking for ideas and explaining one's vision of incorporating the industry needs into the curriculum—but not asking for money right away—was key to get successful buy-in. In addition, the vision of involving students to actually build the laboratory test stand was received very well by the industry representatives. As a result, several companies stepped up and donated cash, parts and labor to help making the three simulators (see Final Products) a reality. In addition, an ASHRAE Senior Undergraduate Project Grant was secured for additional funding for the Air Duct Simulator.

## **Connecting Students and Industry**

As was found from the outreach to the industry, laboratories related to building HVAC&R were needed. Before recruiting students for the senior design projects, kick-off meetings with representatives from the local industry were held to secure buy-in and contact information so students could get into direct contact with the industry. Since the projects were part of the senior

design course, four students worked on each project and the project length was one semester. The first meeting with the students was used to establish the project expectations, and to provide them with contact information from the industry representatives. The approach taken by the faculty supervising the project—different from the faculty teaching the senior design course which monitored all senior design projects but did not actively participate in the technical details of the projects—was to take the role as a client for the product to be designed and delivered. Weekly meetings were scheduled to update the client about the status of the project. This "hands-off" approach worked successfully for all three projects, allowing the students to not only come up with their own design and be creative, but also take ownership of their project. There were only minor interaction between the "client" and the industry representatives, primarily the students were responsible to contact the representatives and explain what they needed. Similar to "real life" engineering, what students designed for was not always available and they had to apply their engineering skills to find a solution. For example, for the Air Handling Unit Simulator a chiller system was not available, so the students used a window air conditioner to chill a water-glycol mixture, and used a donated VAV box and its heating coil as a cooling coil. Another benefit of having the students cooperate with the industry is that students get exposed to budgetary constraint. For example, for the Air Duct Simulator the budget available was \$4,200 as a result of the ASHRAE Senior Undergraduate Project Grant. Although this amount covered some of the cost of material and instrumentation, the students had to contact a sheet metal company to solicit help. Although there was already buy-in from the sheet metal company as a result of the kick-off meeting with the faculty, having the students contact them and figure out how their design could actually be built was an excellent learning opportunity. Besides equipment and labor donations, students also benefited from a safety training for variable frequency drives which are used in the Air Handling Unit and Air Duct Simulators. As shown in Table 1, students had to cooperate with several companies providing them with practice in communicating on a professional level and management skills. Note that some companies were involved in more than one project, a total of six companies were involved.

**Table 1 Overview of Projects**

Project Title	Total Cash Spent	Donations	Number of Companies Involved	List Price of Comparable Simulator from Quotes
Air Duct Simulator	\$4,200*	Labor and Parts	4	\$62,000
Air Handling Unit Simulator	\$1,300**	Labor and Parts	4	\$158,000
Refrigeration Simulator	\$4,500**	Labor and Parts	2	\$30,000
<b>Total</b>	<b>\$10,000</b>	<b>\$15,000***</b>	<b>6</b>	<b>\$250,000</b>

\* ASHARE Senior Undergraduate Project Grant

\*\* Cash donations from Industry

\*\*\* Estimated based on information provided by companies

In Table 1 the total cash spent for all three projects was \$10,000 and the value created, based on list prices from quotes from educational laboratory equipment sellers, is \$250,000. Including the estimated cost from companies for labor and parts, this is a 10:1 ratio for the return of the investment. It should be noted that educational laboratory equipment sellers will most likely give universities an educational discount. However, even with an educational discount it is unlikely that even one of the three simulators listed in Table 1 could be bought with the \$10,000 that was donated by companies and the ASHARE Senior Undergraduate Project Grant.

## **Project Descriptions**

Below are the descriptions as provided to the students groups at the start of the projects. As already mentioned, one key factor for success was to give students only the bare minimum requirements without being too specific. As one student group explained it later in their project report, "a large amount of freedom was allowed for creative construction in the initial client meeting".

### **Air Duct Simulator:**

Design, construct and test an air duct simulator having a fan with variable air flow rate, several duct branches, dampers to control air flow through the branches, devices to measure air flow and static pressure. The finished unit has to be safe for use around students in an educational setting.

### **Air Handling Unit Simulator:**

Design, construct and test a fully functional Air Handling Unit simulator which can heat, cool, humidify, and dehumidify a space based on setpoint operating parameters. The design should include an economizer with controllable dampers, a VFD controlled fan, a heating and cooling coil, a humidifier, instrumentation to measure temperatures, air flow rates, energy input for heating and cooling, and humidity. A building automation system has to be implemented into the design. The finished unit has to be safe for use around students in an educational setting.

### **Refrigeration Simulator:**

Design and construct a laboratory unit air conditioning system having a cooling capacity comparable to that of a window air conditioner. Measurements of temperature, pressure, and refrigerants flow rates must be incorporated. The finished unit has to be safe for use around students in an educational setting.

Weekly meetings were held between the "client" faculty and the student groups. The student groups had to give two update presentations during the semester as part of their senior design course requirements and a final presentation. The "client" faculty also required that the finished unit is handed over at the end with a report, which coincided with the report requirements for the senior design course and therefore did not cause extra work for the students groups working on the three simulators.

## **Final Products**

Since the final products have been designed, created and tested by the students, the students' description as mentioned in their final report are used here to give a short summary of each

simulator, the purpose and functionality. It should be emphasized here that—as a result of the involvement of the industry—the simulators include state-of-the-art equipment and meet the quality standards expected by the engineering profession, in this case the HVAC industry.

#### Refrigeration Simulator:

"A small window air conditioning unit was disassembled and each component was installed on its own individual panel. Each panel can be mounted on a custom built frame. This educational instrument will be incorporated into the curriculum of the Thermal System Design Laboratory course as a practical demonstration of the fundamentals of a refrigeration cycle. By using the Refrigeration Simulator, students will be able to gain hands-on experience with common components of a refrigeration system, see how each component serves the system, and explore the optimization process. This apparatus will also be used as a template to build similar units in the future, so that students will be able to build more complex thermodynamic processes by combining systems. This unit is designed to be flexible to allow for its use in multiple laboratory demonstrations, safe for students to use in a classroom setting, and a fun and valuable addition to the University of Alaska Anchorage."

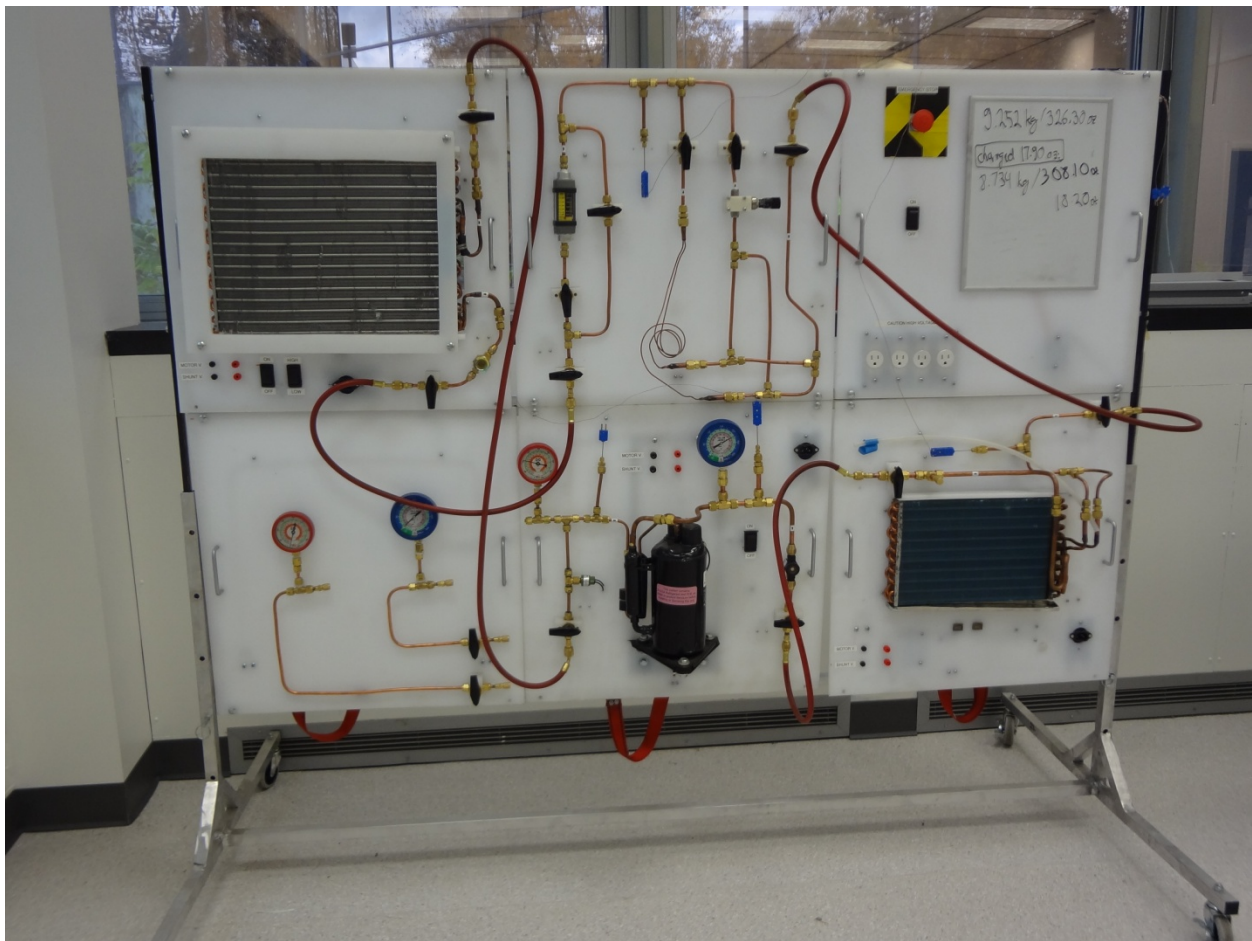

**Figure 1 Refrigeration Simulator**

## Air Duct Simulator:

"The Air Duct Simulator has a variable frequency drive (VFD) which controls a centrifugal fan. The duct network has three branches, each with a manually controlled damper. The top branch houses a removable filter, which is a typical industry filter. The middle branch is generic having two outlets. The bottom branch has three diameters, which narrow from the beginning to end to provide a method of evaluating static regain in ducts. Throughout the system pressure ports are installed to provide velocity and static pressure measurements. The ports are connected to a central location and several liquid and digital manometers can be used to measure pressures. The velocity pressures can be converted to air speed, which when combined with the duct diameter, result in the total volumetric flow rate of the air. Some of the objectives that students will be able to accomplish are create system curves, analyze fan curves, analyze fan efficiencies, and calculate pressure drops across various components. The system can be modified using manual dampers, adding or removing a filter, increasing or decreasing the fan speed, and regulating air flow through branches. The long term results of this project will include teaching future engineers how to fully optimize a system to reduce energy costs, promote better indoor air quality, and implement solutions to various HVAC concerns in the industry."

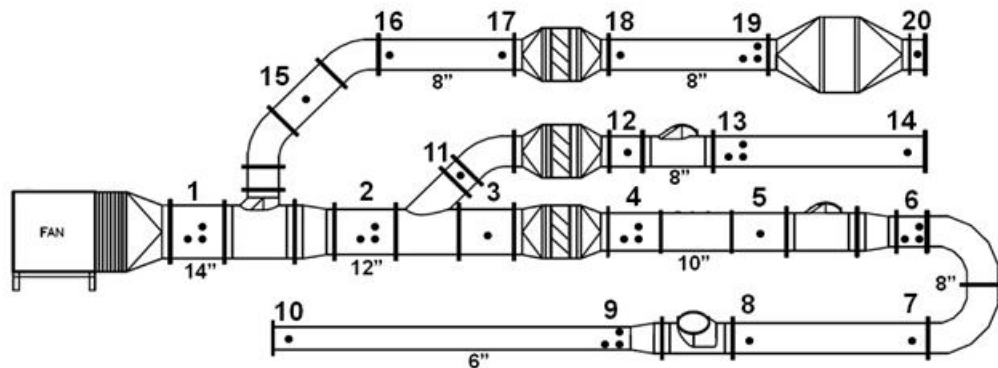

**Figure 2 Air Duct Simulator Schematic and Picture**

### Air Handling Unit Simulator:

"The simulator design includes a VFD controlled fan, duct humidifier, electric heating coil, zone control unit with cooling provided by a window air conditioning unit, economizer with actuated dampers, and a conditioned space. Also present are sensors to monitor temperature, humidity, pressure, and electrical current of various points in the simulator.

By giving students a hands on laboratory device they get to see with their own eyes how air is conditioned. The students will have a better understanding of the material they are learning in the classroom and will gain practical knowledge of the components in air handling systems. The students themselves will be better equipped to design such systems themselves and will see increased confidence in their own knowledge of HVAC design and confidence in their analytical system calculations. It is hoped that from this simulator students will be able to enter into the HVAC industry with a better initial understanding of HVAC control and design."



**Figure 3 Air Handling Unit Simulator**

### Results and Discussion

Besides the successful completion of the projects, a survey was given to the students to analyze how they perceived working on the projects impacted their educational experience. The survey, as given to the students, is shown in the Appendix. Out of a total of 12 students—three projects, four students per project—nine answered the survey.



## Student Survey Results and Discussion

The results of Questions 1 through 3 are summarized in Table 2.

**Table 2 Results for Question 1, 2 and 3**

Choices	Question 1 Responses	Choices	Question 2 Responses	Choices	Question 3 Responses
Much worse	0	Much Less	0	Very Bad	0
Worse	1	Less	1	Bad	1
The Same	1	The same	3	Neither	0
Better	1	More	2	Good	2
Much better	6	Much More	3	Very Good	6

The results for Question 1 shows that six students understand the engineering design process much better after finishing their project compared to other projects they encountered during their student career. Question 2 was aimed to see how students perceive their previous knowledge gained from course work that was required for this project on a comparative basis to previous projects the students took. The results show that the majority of students perceived that they had to use more knowledge from previous coursework for this project compared to other projects they were involved in previously. For Question 3, eight out of nine students rated their experience with their project as good or very good.

The results from Question 4 show that eight out of nine students would recommend to other students to sign up for similar projects—building equipment for a thermal system design laboratory. One student answered Question 4 with no. Question 4 had a logic built in and the one student who answered no to Question 4 provided the following comment why he/she would not recommend to other students to sign up for similar project: "There is already 2 or more Labs being built currently. Spread the student projects around." The students comment is probably aimed at the fact that he/she wishes to have more variety of senior design projects since two of the projects—Air Duct Simulator and Air Handling Unit Simulator—took place in the same semester. Therefore, it seems the student comment is more aimed at the distribution of senior design projects and not directly at the project he/she was involved in. Seven students answered the follow up question why they would recommend to other students to sign up for projects requiring to build equipment for a thermal system design laboratory:

"Students will be involved in creating a physical system with hands on components. Physical components are not ideal and students can see how different a physical system truly is compared to the idealized paper version. It (hopefully) creates a partnership with some of the local industry. Talking and meeting with the local industry helps engineering STUDENTS understand what the actual engineering PROFESSIONALS have to deal with in real world applications. It provides a link between the senior level students and the university for the future. Hopefully, the senior level students feel some sense of accomplishment and an attachment to the quality of the university. The university is no longer just a place where a student gets a degree, there is more commitment to the university, more school spirit / pride, etc."

"Building equipment provides useful experience with industry contacts as well as critical thinking and design considerations. Manufacturing constraints are also very important to consider when designing, and working with industry professionals to learn manufacturing constraints helps with streamlining a initial design, and can also help with identifying possible issues before they happen so that they can be prevented."

"Thermal systems are everywhere, it's one of the things that will likely never go away. Learning how to design and build your own system greatly enhances the knowledge of what is really involved in making it work. And it actually has a fun factor to it, I enjoyed doing this project with my team."

"Encouraged collaboration with people outside of academia, and gave a glimpse of real world design. It is more likely that designs will be based around available parts and funding, versus what might be ideal. Performance compromises will always exist."

"It helps with gaining a "real world" understanding of how HVAC systems work. Good experience with working on a team. Good experience with how unexpected issues can effect a project."

"The University of Alaska Anchorage is trying to build up their programs, and acquiring more hands-on lab equipment is an important component of that effort."

"Dr. Peuker was instrumental in the work we had done. [...]\*" In senior design in this particular project we invested a lot more time an energy than your typical senior design group.[...]\* I felt that it was a great learning experience. I would definitely recommend them to others."

\* edited out content which commented on course work related to another course, not the senior design project.

Eight student answered Question 5 and all agreed that the involvement of the industry benefited their projects.

Eight student responded to Question 6 and Table 3 shows the results.

**Table 3 Results for Question 6**

Assuming your project would have been offered to you as one of the options below. Would you have signed up for the project? Please select all that would apply to you.

Choices	Responses	Percent
The project would count as a 3 credit technical elective	7	88%
You would not get academic credit for the project, but you would be paid, e.g, \$10.50/hr	4	50%
The project is offered as a summer internship with pay	4	50%
The project is offered as a summer internship without pay	4	50%
The project is offered as an engineering experience, no academic credit, no payment	2	25%
I would only sign up for the project if it would be offered as part of senior design	3	38%

Interesting to note from Table 3 is that at least half of the students would participate in similar projects as long as the students get paid, receive academic credit or the project is part of an internship. Two students would even sign up for a project without any tangible benefits. Table 3 also shows that if a senior design project is not feasible for whatever reason, 88 percent of the students would be willing to take on similar projects as a technical elective, which could be offered as an independent study, for example.

Question 7 gave students the opportunity to comment positive and negative aspects of involving undergraduate students in building laboratory simulators. Eight students replied:

"Definitely, when students build something, it allows other students to see the design process. There's a definite difference between student built and professional built products. The first helps students more, the second looks prettier."

"Positive aspects include: \*\*Enhanced learning of the overall engineering design process.\*\*"

"Positive aspects include: developing team work skills, promote participation in industry, improve critical thinking skills, increase understanding of the topic, provide invaluable engineering experience (seeing a project through, from a paper sketch to reality). Negative aspects include: the project may seem overwhelming, may not have a clear starting point, may be difficult to predict or construct a work schedule, may be time consuming."

"As mentioned before, the knowledge gained from this project is tremendous in understanding systems that will always be present. There really wasn't a negative aspect, we learned a great deal of the engineering and industry worlds that help prepare us for the real world after graduation."

"I think it is important for the students involved in the project, but not necessarily for the students using the lab equipment."

"I think designing and building a piece of equipment gives valuable experience and deeper understanding that cannot be easily gained any other way. As we struggled to make our design work, we learned a lot of things which can't be taught effectively in a classroom."

"I enjoy working and learning with my hands, so assembling something myself provides me with an understanding of how it works that cannot be gained another way. I particularly like the idea listed above of offering students a paid summer internship to build laboratory equipment, I think that would be a valuable opportunity to apply previous knowledge and learn new skills, as well as a way to make students feel more invested in their program."

"Undergraduates are not really needed to design the apparatus we had built. Anyone who is willing to put in the time and has some skill, with the direction of the faculty can design such a device. But the project benefitted everyone involved. The university got a workable device that can be used for a lab nearly for free. The undergraduates benefited by gaining useable skills required in the construction of our design. Also a student may not ordinarily have the budget or

the time to put such a device together on their own. We didn't always have the tools to build the device and we had to make due a lot of times. But I am proud of what we had constructed."

Question 8 asked if the students would support—financially and/or providing donations—senior design projects at the University of Alaska Anchorage assuming they are in a position in a company which allows them to make such decisions. Five out of eight students answered yes, two answered maybe and one student answered no.

Question 9 allowed students additional comments and five students left an additional comment.

"I believe more benefit to students would be had if cross disciplines were given projects. I had a personal project that could have been done with a couple mechanicals, and an electrical, maybe also a computer person. I think there would be a large benefit to taking on a project where a broader engineering experience would be achieved."

"Looking back on the project process and with the amount of help that was received for this project from the local industry, it is conceivable that the project could have been completed with smaller group sizes. From what I remember, the initial few weeks of the project were filled with some uncertainty about exactly how the system should be designed. A smaller group of 2-3 (or even a single student) could have made a critical decision on the design much quicker. This comment leads to the next one. I think a bit more initial advisor/client insistence to contact the industry with ideas and finalize the design would have made the final few weeks less hectic. However, maybe that's a positive so that students can learn how to prioritize their project timelines. Depends on the end goal: either a completed system by a specified date OR a learning process for senior engineering students. The final product did turn out to be a success, which is primarily due to the local industry assistance. I think this is the biggest positive out of the project. From what I gather, the backbone of the projects are the partnerships and "sub-contracts" that engineers must coordinate. Overall, an enjoyable project process that turned out great. I would have done some things differently looking back, but I'll just have to remember that for future projects."

"Overall the project was very educational and I would recommend it to any and all students who wish to have a challenge. Though the project was time consuming, I saw it as a good experience that will help prepare students who participate in similar projects for the expectations placed on them as they enter the work force."

"I quite enjoyed working on this project with my teammates."

"I feel our project was substantially more involved than the vast majority of other senior projects, and I am glad to have been a part of that team."

Summarizing the feedback from the students it is evident that the cooperation between the industry and the students is the single most important aspect of assuring the success of the projects and provided a unique educational experience for the students. It is also evident that all projects required a significant time commitment from the students, more so than other senior design projects. However, the students comments show that they are willing to invest more time

because the benefits—experience working together with industry, better understanding of the engineering design process, developing team work skills, improving critical thinking skills—are worth the additional time investment. A certain pride can also be found in the comments, students felt they accomplished something of lasting value. This also evident in the reports, for example, from the following paragraph from the Air Handling Unit Simulator report:

"The air handling simulator also shows what the engineering students at the University of Alaska Anchorage are capable of. It shows the quality of the engineering program at the University of Alaska Anchorage and what students are capable of accomplishing, while companies in Alaska should be able to look at the scope of a project such as this and feel more confident that the University of Alaska Anchorage graduates are ready to enter into the workforce."

### Industry Survey Results and Discussion

The six companies involved with the three projects were also contacted to provide anonymous feedback, two provided written feedback which is quoted here. When asked for the reasons why to support the development of educational equipment for the Thermal Systems Laboratory at the University of Alaska Anchorage the replies were that "it is extremely important that Mechanical Engineering students have the basic HVAC concepts and the opportunity to learn firsthand, by utilizing hands on equipment" and that "these simulators and labs allow students to train on relevant equipment they will interface with if they enter the HVAC industry. This helps get students beyond theory and shows them real life examples. One of the difficulties in hiring new engineers are they have been taught in college the right answer is in a book. Outside of school there are often many answers to a question and often there is no book on the subject. They must learn through labs and well structured senior designs that answers are derived and are not found." When asked about the importance of involving undergraduate students in the design and building of laboratory equipment the following answers were given:

"Absolutely: 1. Real life experience/on-the-job-training is some of the best training these students will receive. 2. Allows them to actually implement what they have learned in the classroom.  
3. Allows them to work in a team. This can sometimes be challenging for some students/engineers and working on these projects, opens the door on real life work situations.  
4. Opens the door for networking with industry leaders.  
5. Sense of pride completing a project that will be used by future students at UAA."

"I think it is good only if the students are asked to do this in collaboration with industry partners. In my mind senior designs should be utilized to expose students to real life design processes. Emphasis on processes. Most university classes teach a lot about how to do calculations and how to select things but the senior design course is the only place that allows the processes to be learned."

All companies—not only the two which provided written feedback—expressed interest to periodically visit the laboratory and to donate time and/or equipment in the future.

## Conclusion

This paper demonstrates that thermal system design teaching laboratory equipment—in the presented case an Air Duct, Air Handling Unit and Refrigeration Simulator—can be successfully built through a student industry cooperative approach within one academic year without any institutional funding. Comparing the cash and material donations to buying comparable equipment from commercial sources showed a return ratio of 10:1 for the investment. Furthermore, as a result of the involvement of the industry, the simulators include state-of-the-art equipment and meet the quality standards expected by the engineering profession, in this case the HVAC industry.

For a successful buy-in from industry to support developing a thermal system design undergraduate teaching laboratory it was found that personal networking by the faculty is key and that the industry was more willing and interested to support undergraduate senior design capstone projects to develop laboratory equipment than providing cash donations.

The student and industry feedback—gathered through anonymous surveys—indicates that the cooperation between the industry and the students is the single most important aspect of assuring the success of the projects. In fact, the students and industry partners agreed unanimously that the involvement of the industry benefited their projects. Based on the student feedback, the student-industry cooperative approach provided a unique educational experience and aided the students to better understand the engineering design process, develop team work skills, and improve their critical thinking skills.

## Appendix

### Student Survey

The following questions are for the study to investigate the student industry cooperation for the development of thermal system design teaching laboratory equipment. Please do not answer the following questions if you did not sign a consent form to participate in this study. Thanks!

Q1 Compared to other projects during your student career, this senior design project helped me to understand the engineering design process.

- Much Worse
- Worse
- About the Same
- Better
- Much Better

Q2 Compared to other projects during your student career, this senior design project required the application of knowledge gained in previous coursework.

- Much Less
- Less
- The Same
- More

Much More

Q3 Please rate your overall experience with your project.

- Very Bad
- Bad
- Neither Good nor Bad
- Good
- Very Good

Q4 Would you recommend to other students to sign up for a senior design project which requires to build equipment for the Thermal System Design Laboratory?

- Yes
- No

If Q4 "Yes" Is Selected:

Name a couple of reasons why you would recommend to other students to sign up for a senior design project which requires to build equipment for the Thermal System Design Laboratory.

If Q4 "No" Is Selected:

Name a couple of reasons why you would not recommend to other students to sign up for a senior design project which requires to build equipment for the Thermal System Design Laboratory.

Q5 Did the involvement of the local industry benefit your project?

- Yes
- No

Q6 Assuming your project would have been offered to you as one of the options below. Would you have signed up for the project? Please select all that would apply to you.

- The project would count as a 3 credit technical elective
- You would not get academic credit for the project, but you would be paid, e.g, \$10.50/hr
- The project is offered as a summer internship with pay
- The project is offered as a summer internship without pay
- The project is offered as an engineering experience, no academic credit, no payment
- I would only sign up for the project if it would be offered as part of senior design (ME 438)

Q7 Your design will be used by other students when they take the Thermal System Design Laboratory course. Do you think it is important to involve undergraduate students, like yourself, in the design and building of laboratory equipment? Please elaborate on the positive and negative aspects.

Q8 Would you support, financially and/or providing donations, senior design projects at the University of Alaska Anchorage assuming you are in a position in a company which allows you to make such decisions?

- Yes
- Maybe
- No

Q9 Please use the space below to add any additional comments. Thanks!

#### Bibliography

1. Bidana, B., and Billo, E.R., "On the Use of Students for Developing Engineering Laboratories," *Journal of Engineering Education*, pp. 205-213, April, 1995.
2. O'Connell, R., Moore, M., and Zimmerschied, K., "Using Students Projects to Develop Laboratory Experiments for the Power Electronics Course", *2008 Annual Conference and Exposition*, AC 2008-1323, Pittsburgh, PA.
3. Webster, J.G., "Student designed laboratory experiments in biomedical instrumentation," *Proceedings of the IEEE*, vol.59, no.6, pp. 985- 986, June 1971