

Modeling and Simulation of 6-Pulse and 12-Pulse Rectifiers under Balanced and Unbalanced Conditions with Impacts to Input Current Harmonics

Arief Hernadi⁽¹⁾, Taufik⁽²⁾, and Makbul Anwari⁽³⁾

⁽¹⁾⁽²⁾ Electrical Engineering Department
Cal Poly State University
San Luis Obispo, CA 93407 USA
ahernadi@calpoly.edu
taufik@calpoly.edu

⁽³⁾ Department of Energy Conversion
Universiti of Teknologi Malaysia
Skudai, Malaysia
makbul@ieee.org

Abstract

This paper discusses the impact of using 6-pulse and 12-pulse rectifier circuit commonly found in Adjustable Speed Drives. The 12-pulse topology is known to be more expensive, but produce the least input current harmonics. However, the latter statement is completely true under balanced line conditions. In practice, the lines are inherently unbalanced. Hence, the question of whether the 12-pulse rectifier will indeed perform better in terms of the harmonics injected to the line is still under on-going discussions. This paper presents the modeling and simulation of both rectifier topologies to compare their input current harmonics. The rectifiers are modeled using OrCAD Pspice and several common cases of line conditions will be simulated to compare their harmonic levels. Results of the simulations pertaining to their Total Harmonic Distortions for each case will be explored.

1. Introduction

As technology grows everyday, the study of power systems has shifted its direction to power electronics to produce the most efficient energy conversion. Power electronics is the study of processing and controlling the flow of electric energy by supplying voltages and currents in a form that is suited for user loads [1]. The goals of using power electronics are to obtain the benefit of lower cost, small power loss and high energy efficiency. Because of high energy efficiency, the removal of heat generated due to dissipated energy is lower. Other advantages of power electronics are reduction in size, weight, and overall cost.

Like other technologies, power electronics has certain disadvantages. One major shortcoming is the generation of harmonic voltages and currents. To filter

out harmonics, more components and money would be needed for a given project. Having harmonics produced by power electronics will result in upstream losses in windings and in transformers in the system.

A rectifier is a power electronic circuit that is used to convert ac signals into dc signals. A rectifier is a “power processor that should give a dc output voltage with a minimum amount of harmonic contents” [2]. When a polyphase ac is rectified, the phase-shifted pulses overlap each other which produce a smoother dc output than that made by a single-phase ac rectifier. This is considered as an advantage in high-power rectifier circuits, where the actual size of filtering components would be prohibitive in spite of their necessity to obtain low-noise dc power [3].

When a three-phase input is available, rectifiers can come in a variety of pulses such as the 6-pulse and 12-pulse. As the number of pulses increases, the input characteristic improves. This results from a greater number of pulses in a given period which is due to the larger number of diodes used. This, in turn, makes the 12-pulse rectifier more costly. However, the analysis commonly done to exhibit the advantage of lower input harmonics for the 12-pulse is done under steady-state balanced line condition. In practice, line condition is inherently unbalanced due to the fact that the three-phase lines are loaded differently in each of its three lines. Therefore, the study of how input current harmonics are impacted under unbalanced line conditions should be conducted to help determine cost vs. benefit considerations when implemented in commonly used controllers such as the Adjustable Speed Drives. Such study using hardware implementation has been done and was reported in [4]. However, the study was performed under certain operating conditions and the results are not representative of any other conditions in general. Besides, the actual system implemented for the study

can be quite costly, thus it will be impractical to perform similar study for other operating conditions. Therefore, the most economical and practical method to perform this study is through the use of computer simulation.

This paper describes the modeling of 6-pulse and 12-pulse rectifiers operating under unbalanced conditions. Examples of case studies were performed using the model and results will be presented. The model uses Orcad Pspice and could be easily adapted to learn the impact of any unbalanced conditions to rectifier's input current harmonics.

2. 6-Pulse and 12-Pulse Rectifier Models

Figure 1 shows schematic of the 6-pulse bridge rectifier using Orcad Capture. The input represents three-phase voltages whose amplitude may easily be adjusted to any desired values which reflects the percentage of unbalance in the system. The phases of the three phase voltages follow the positive sequence convention. The series resistances on both the primary and secondary sides are needed to prevent convergence and inductance loop errors. The output resistance was chosen to enable users to adjust to the desired rms of

input currents. The transformers represent a Y-Y connected three-phase transformer formed by three single-phase transformers where each is modeled using a part called the K_linear. The turns ratio (N_S/N_P) of each transformer can be conveniently adjusted by the value of their primary (L_P) and secondary (L_S) inductances following equation:

$$\frac{N_S}{N_P} = \sqrt{\frac{L_S}{L_P}}$$

For the model presented in this paper, as shown in Figure 1, a turns ratio of 1:1 was selected. Since all three single-phase transformers use the same turns ratio, the part called PARAMETERS is being used. The part allows users to define some global parameters whose values may be used repetitively in any of the components on the schematic. The diodes in the schematic are closed to an ideal diode model called the Dbreak diode. With this diode model, users may conveniently adjust diode parameters most suited for their applications.

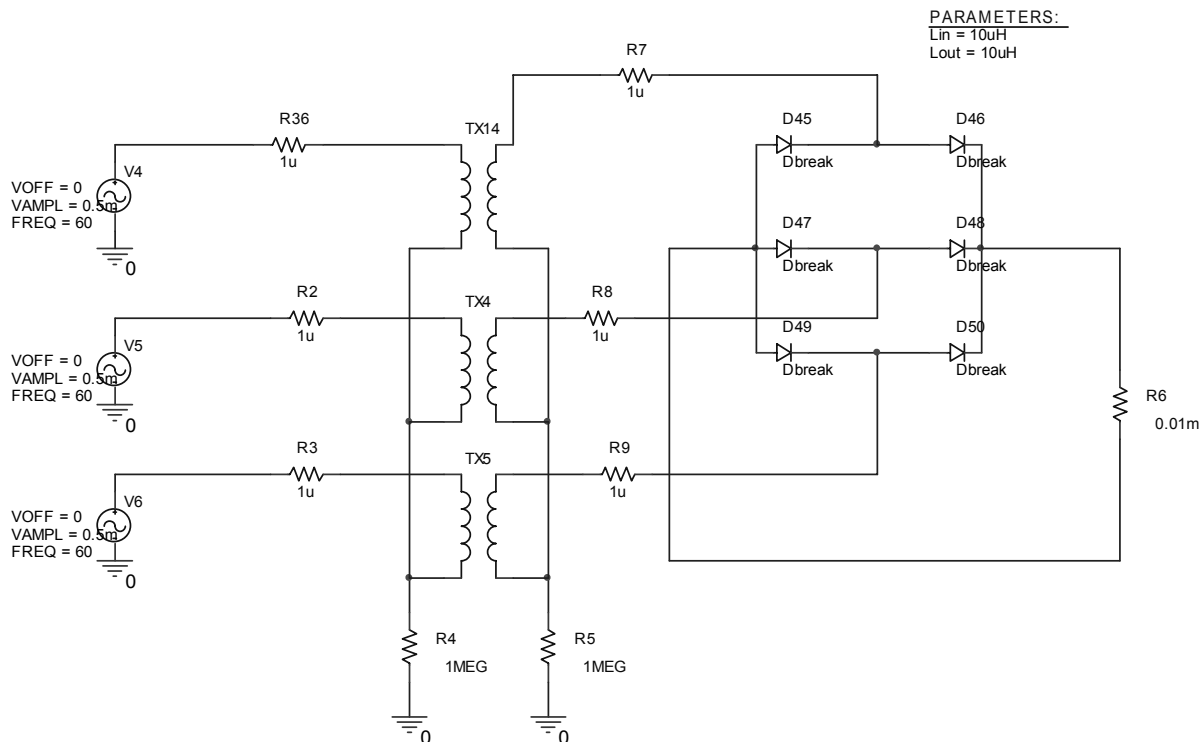

Figure 1. 6-Pulse bridge rectifier schematic

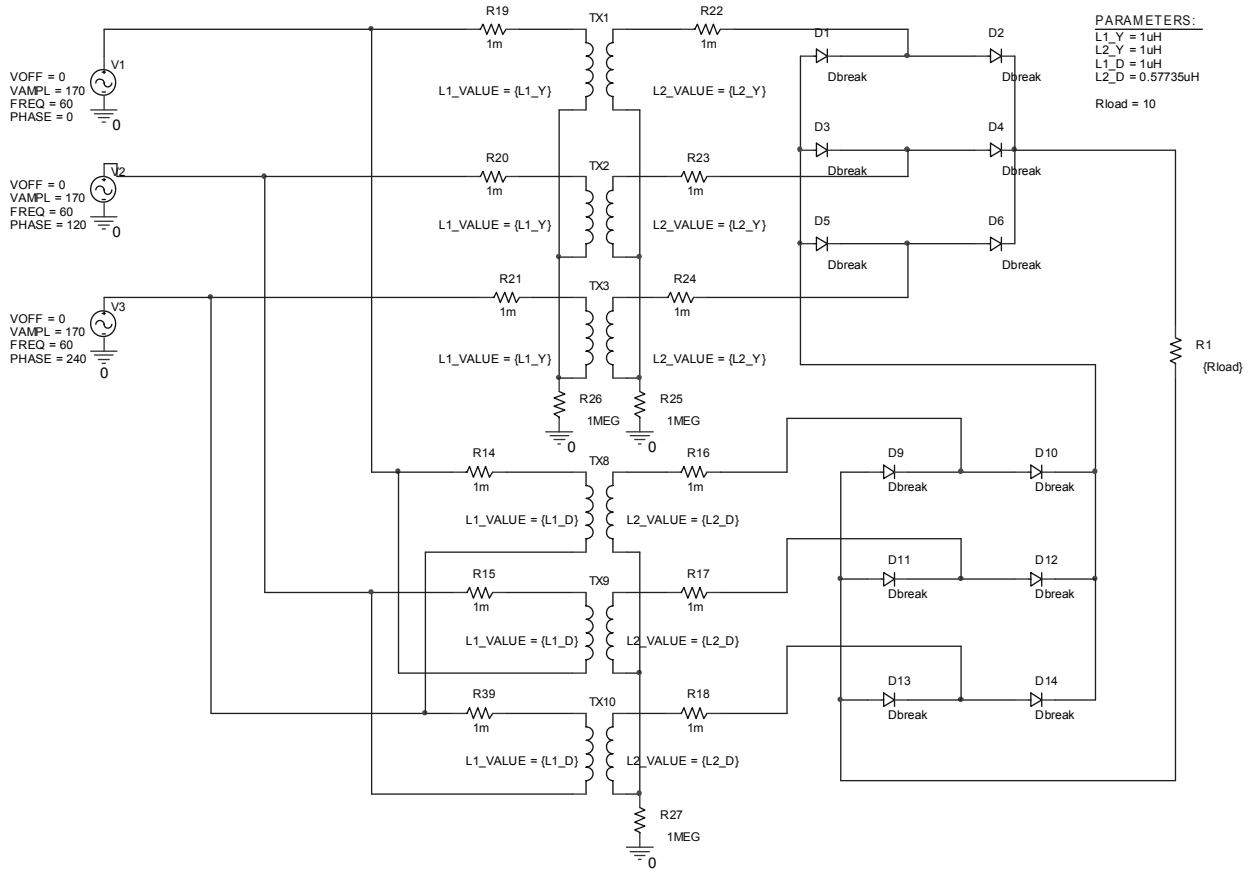

Figure 2. 12-pulse bridge rectifier schematic

Figure 2 depicts the 12-pulse bridge rectifier. The model is constructed using two 6-pulse bridge rectifiers in series. The same three phase voltages are connected at the input of both rectifiers. However, as shown in Figure 2, the first rectifier is fed from a Y-Y connected transformer, while the other rectifier is fed from a Δ-Y connected transformer to introduce the necessary phase shift to produce the 12 pulses affect on its dc output. Since the voltage gain in Δ-Y differs from that of Y-Y by a factor of $\sqrt{3}$, hence the turns ratio for the Δ-Y has to be adjusted accordingly, as shown under the PARAMETERS part of Figure 2.

3. Simulation Results

Both rectifier models were simulated. To demonstrate the validity of the models, an example of input line current for the 12-pulse is shown in Figure 3 at 20% (dotted line) and 100% load (solid line). The model indeed draws multiple-step current waveform as one would expect from a 12-pulse rectifier. In this paper, the results of the following case examples will be presented:

1. Balanced 3-Phase System as the baseline case
2. Case 1: Unbalanced with $V_A = 120V + 3\%$, while the other two voltages are at 120V
3. Case 2: Unbalanced with both V_A and $V_B = 120V + 3\%$, while $V_C = 120V$
4. Case 3: Unbalanced with both $V_A = 120V + 3\%$, $V_B = 120V$, and $V_C = 120V - 3\%$

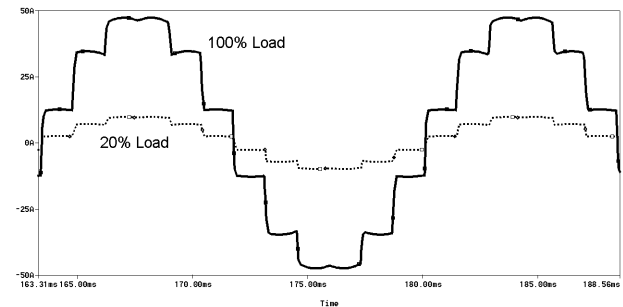

Figure 3. Line current in 12-pulse bridge rectifier

Note that the above cases and voltage values are selected arbitrarily with the 3% variation comes from

common practical tolerance limit typically imposed by utility companies.

Based on the above case examples, results in terms of the total harmonic distortions (THD) of input line currents are presented in Figures 4, 5, and 6. Interestingly, the results in general showcase the advantage of the 12-pulse rectifier over their 6-pulse counterpart. But first, Figure 4 depicts the level of THD for all four case studies done on the 6-pulse rectifier. Although the percentage difference is not significant; however it clearly shows that in certain percentages of load, the balanced system produces THD of input line current worse than that of the unbalanced cases. As evidenced in Figure 4, this occurs when the load is less than 30% or higher than 80%. Moreover, it is interesting to observe that case 1 always produces the least amount of THD.

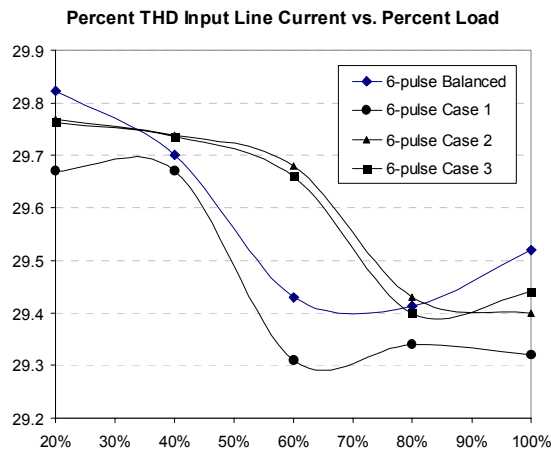

Figure 4. THD line current of 6-pulse rectifiers

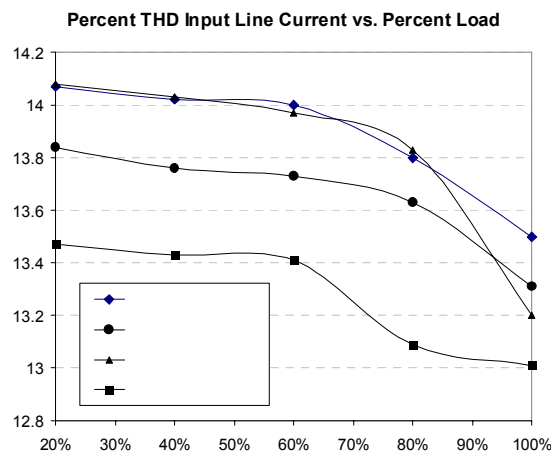

Figure 5. THD line current of 12-pulse rectifier

Figure 5 shows simulation results of the 12-pulse rectifier. It clearly shows that case 3 always yields the least amount of THD, while both the balanced

and case 2 overall gives out the highest THDs. It is also interesting to note that under balanced system, the THD line current is significantly better at load higher than 80%.

Figure 6 combines results from both the 6-pulse and the 12-pulse rectifiers to compare performance of both rectifiers. As can be seen from Figure 6, the 12-pulse rectifier clearly outperforms the 6-pulse in all four case examples. This surely justifies the higher cost of the 12-pulse as compared to the 6-pulse. The difference in the THD of line current can be as much as 17%. In practice, this translates to higher filtering requirement for the 6-pulse which add up to the installation cost. One very interesting finding is that the THDs for both 6-pulse and 12-pulse rectifiers in all four cases are quite flat or stable over load variation. This provides convenience when it comes to sizing the harmonic filters at the input.

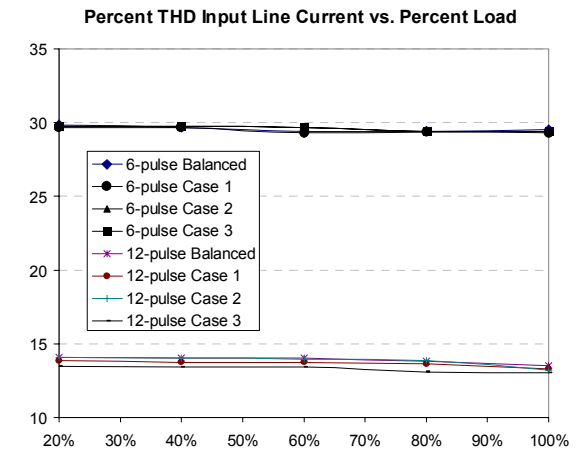

Figure 6. THD line current of both 6-pulse and 12-pulse bridge rectifiers

4. Conclusion

Modeling and simulations of two commonly used bridge rectifiers were presented and discussed in this paper. The models make use of Orcad schematics whose lite version is available for free and downloadable from their company's (Cadence) website. The simulation was realized to be very flexible and economical to study performance of these rectifiers under numerous practical conditions which will otherwise be very expensive to put together. With simulations, engineers will be able to predict before hand the level of harmonics of input current that they will be dealing with under three-phase system that they are accustomed to.

To demonstrate the validity of the models, four case examples were simulated on the models to show

the impact of unbalanced system to their THD input line current. Results were presented and discussed in this paper. However, one crucial point is that although the models are based on mostly ideal components, users may easily modify the models to a more realistic one by simply adding parameters such as resistive losses or more comprehensive diode models.

5. References

- [1] Mohan, N., Undeland, T., and Robbins, W., *Power Electronics: Converters, Application and Design*, John Wiley and Sons Inc., 2002.
- [2] Rashid, Muhammad H., *Power Electronics Circuits, Devices, and Applications*, New Jersey: Pearson Prentice Hall, 2004.
- [3] "Ask the Experts", The EC&M Magazine, December 1, 2002.
- [4] Hink, Karl M., "Harmonic Mitigation of 12-Pulse Drives with Unbalanced Input Line Voltages", MTE Corporation.