

HEPA Filter Repair Tooling

Sponsored by the Lawrence Livermore National Laboratory

A Senior Project Report

Submitted to the Faculty of the
Department of Mechanical Engineering

By

Phillip Blacklock & Adam Tackitt

Date: May 27, 2012

Advisor:

Dr. Mohammad Noori

Sponsor:

Erik Brown, LLNL

Abstract

This report summarizes the design and fabrication of tooling and a process that will be used to remove and replace a single filter element in an array of elements. This is a one-off design for the Lawrence Livermore National Laboratory and will be used to remove a single ceramic cylindrical style HEPA filter that is adhered to a punch flare by a fire proof sealant. The methods used to achieve this goal are: 1) Researching and testing the filter element and adhesive material properties, 2) preliminary designing and prototyping of tool, 3) testing and analysis of original design, 3) redesign, 4) final tool designing and manufacturing, and 5) final design testing, analysis, and reporting.

Acknowledgements

We would like to thank Erik Brown at the Lawrence Livermore National Laboratory for all of his help and insight throughout the project and our advisor Dr. Mohammad Noori for sending us in the right direction.

Letter of Transmittal

May 27, 2012

To: Dr. Mohammad Noori and Erik Brown

From: Phillip Blacklock & Adam Tackitt

This report has been written to document the HEPA Filter Repair Tool senior project progress made by Phillip Blacklock and Adam Tackitt from October 2011 through May 2012. The designs enclosed are for a tool that will be used to remove a single cylindrical ceramic filter element from an array of identical filters. This is our final report for this project. The design has been presented to and approved by both Dr. Mohammad Noori and Erik Brown.

Yours Sincerely,

Adam Tackitt

Phillip Blacklock

Table of Contents

Abstract.....	i
Letter of Transmittal	iii
List of Figures and Tables.....	vi
Nomenclature.....	viii
1. Introduction	1
2. Background.....	2
3. Preliminary Design Development	5
3.1. Preliminary Analysis	5
3.1.1. Sealant Cutting and Tube Pulling.....	6
3.1.2. Filter Cutting and Grinding Test	7
3.2. Discussion of Preliminary Concepts	9
3.2.1. Sealant Cutting and Filter Pulling Concepts.....	9
3.2.2. Multi-Purpose Concept.....	13
3.3. Concept Decision	16
4. Final Design Concept	17
4.1. Clip Design.....	17
4.2. Slider Design.....	18
4.2.1. Bearings.....	19
4.3. Steel Protective Guide Tube.....	19
4.4. Filter Removal.....	21
4.5. Grinding Excess	22
4.6. Protective Sleeve.....	22
4.7. Sealant Injector.....	23
5. Final Design Prototype	24
5.1. Clips	24
5.2. Slider	24
5.3. Sealant Injector.....	25
5.4. Pusher Shaft.....	26
5.5. Knob.....	26
6. Final Design.....	28
6.1. Clips	28
6.2. Pusher Shaft.....	28
6.3. Knob	28
6.4. Pusher Plate.....	29
6.5. Shafts.....	29
6.6. Slider	30
6.7. Protective Tube	31
6.8. Wire Brush	32
6.9. Punch.....	33

6.10.	Sealant Injector	33
6.11.	Sealant Injector Handle	34
6.12.	Sealant Injector Extension	34
6.13.	Protective Tube Riser	34
6.14.	Sealant Drying Cap.....	35
7.	Operation Procedure	36
7.1.	Tool placement.....	36
7.2.	Removal of Filter Element	38
7.3.	Removal of Remaining Filter Material, and Sealant.....	39
7.4.	Applying New Sealant	40
7.5.	Install New Filter Element	41
7.6.	Removal of Steel Protective/Guide Tube.....	42
8.	Conclusion.....	43
9.	References	44
10.	Appendices.....	45

List of Figures and Tables

Figure 1. Russian Design for HEPA Filters..... 2

Figure 2. Filter Array Configuration..... 2

Figure 3. Filter assembly cutaway showing airflow movement..... 4

Figure 4. Punch Flare..... 5

Figure 5. Single Filter Test Element..... 6

Figure 6. Linear Force Gages in Test Positions..... 6

Figure 7. Diamond coated cutting wheel in position..... 7

Figure 8. Wire brush in position..... 8

Figure 11. Remaining filter section..... 9

Figure 9. Result from wire brush..... 9

Figure 10. Wire brush in action..... 9

Figure 12. Cutting Concept 1..... 10

Figure 13. Cutting concept 2..... 11

Figure 14. Pulling Concept 1..... 12

Figure 15. Pulling Concept 2..... 12

Figure 16. Multi-Purpose Tool Concepts 1..... 13

Figure 17. Multipurpose (Inserting and support) Tool Concept 2..... 14

Figure 18. Inserting Tool Concept 3 Cutaway with Grinder..... 14

Figure 19. Inserting Tool Concept 3..... 14

Figure 22. Tooling to brace off of filter box..... 15

Figure 20. Sealant Applicator..... 15

Figure 21. Sealant Applicator in Position..... 15

Figure 23. Final Tooling Support Design Concept..... 17

Figure 24. Main Tensioning Clip..... 18

Figure 25. Secondary Clip..... 18

Figure 26. Slider..... 19

Figure 27. Linear Slider Bearings, McMaster P/N 6489K62..... 19

Figure 28. Steel Protective/Guide Tube and Slider..... 20

Figure 29. Automatic Center Punch in Position..... 21

Figure 30. Result from Automatic Punch Use..... 22

Figure 31. Protective Sleeves..... 22

Figure 32. Sealant Injector..... 23

Figure 33. Rapid Prototyped Clips..... 24

Figure 34. Rapid Prototyped Slider..... 25

Figure 35. Revision 2 of the Sealant Injector with a Luer Taper..... 26

Figure 36. Knob on the Rapid Prototyped Slider..... 27

Figure 37. Machined Clips..... 28

Figure 38. Knob..... 29

Figure 39. Pusher Plate and Pusher Shaft Assembly	29
Figure 40. Shafts for a 1 Square Foot Filter Box	30
Figure 41. Machined Slider.....	30
Figure 42. Protective Tube with Flange.....	32
Figure 43. Wire Brush with Extension attached to a Drill.....	32
Figure 44. Automatic Punch	33
Figure 45. Final Sealant Injectors for the LLNL	33
Figure 46. Sealant Injector Handle	34
Figure 47. Sealant Injector, Extension, and Handle Assembly.....	34
Figure 48. Protective Tube Riser	35
Figure 49. Sealant Drying Cap.....	35
Figure 50. Filter Removal Tool Installed on Filter Box	36
Figure 51. First Direction of Motion for Aligning FRT	36
Figure 52. FRT Slider motion in Fore and Aft Direction	37
Figure 53. Arrows indicating the two 10-24 cap screws used to secure the Slider	37
Figure 54. Installing Protective Steel Tube.....	37
Figure 55. Arrows indicating the two 10-24 cap screws used to secure Protective Steel Tube ...	38
Figure 56. Automatic Punch in Position.....	38
Figure 57. Removing the Filter.....	39
Figure 58. Hand Drill on Extension to Clean Base.....	39
Figure 59. Clean Base.....	39
Figure 60. Protective Tube Riser Installed	40
Figure 61. Installing sealant injector assembly.....	40
Figure 62. Sealant Injector Assembly in Place.....	41
Figure 63. Sealant Injector Protruding from Punch Flare.....	41
Figure 64. Sealant Filled Syringe attached to Sealant Injector.....	41
Figure 65. Lower New Filter into Position.....	42
Table 1. Design Specifications	1
Table 2. Summary of Applied Loads	7
Table 3. Summary of cutting wheel results	8

Nomenclature

HEPA: High-Efficiency Particulate Air

LLNL: Lawrence Livermore National Laboratory

CNC: Computer Numerical Control

FRT: Filter Removal Tool

1. Introduction

This project has been proposed to us by the Lawrence Livermore National Laboratory to assist them in the design of a tool that will be used on new style of fire proof nuclear facility HEPA filtration system.^[1] Our task is to design a one-off tool, or set of tools, that will be capable of removing and installing a single cylindrical style ceramic filter element from an array of filter elements. This must be done without damaging any of the surrounding filters. Filter elements in the array will be spaced 6-7 millimeters apart and are easily damaged.^[2] In a two foot square box, there will be 188 of these filters.

An accurate scale model will be constructed for testing. To achieve the design goal we will begin by testing the material properties of the filter elements and adhesive used to secure them. Next, we will do a preliminary design and prototype of the tool. After the prototype has been constructed we will test the design on the model we have constructed. Data from the test will dictate if a redesign is necessary. After all design iterations have been performed a final tool will be manufactured. The final design will be completed and presented at the Cal Poly Mechanical Engineering Senior Project Design Expo in May of 2012.

Along the way, we must conform to the design specifications set forth by us and the LLNL. These specifications are summarized in Table 1.

Table 1. Design Specifications

Engineering Specification	Justification
1. Must be used to remove and replace a single filter element in an array of filters	This is the primary goal of the project.
2. Must not damage surrounding filters	Damaging surrounding filters would render the tools useless because it would be impossible to repair all of the filters if the tooling keeps damaging them.
3. Must not require excessive user skill to use the tools	We want tools that anyone can pick up and use with only instruction and not training.
4. The tooling must not start a fire ^[1]	This is a requirement listed by Erik Brown.

2. Background

Because this tool is a one-off design, there is very little background information specific to this process. The LLNL does not currently have any method of removing filter elements that have been attached via the 3M sealant that will be used. A Russian group, however, uses similar filter elements but attaches them in a way that employs fasteners instead of an adhesive, as seen in Figure 1.^[2] This design employs the use of fasteners to hold in the filter

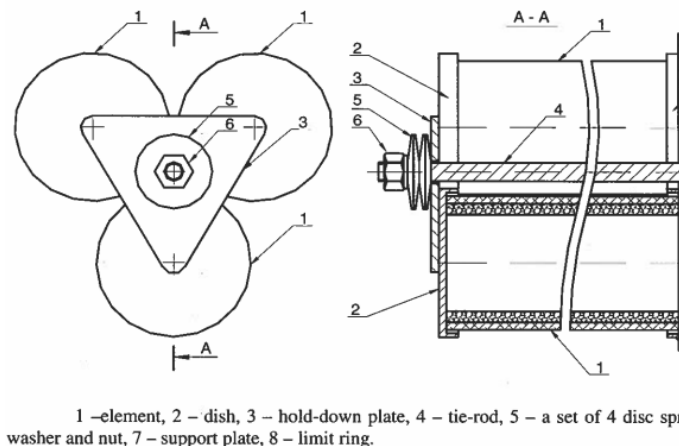
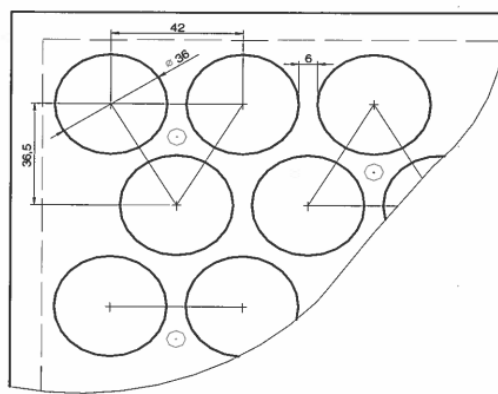

Figure 1. Russian Design for HEPA Filters

elements. Though this design may make it easier to insert and remove filters, the performance is inferior to the design that utilizes an adhesive. Additionally, because there are 188 filters within a two foot by two foot box, the amount of hardware required by this design makes it very heavy and more complex.

Another aspect of the project is that it deals with porous ceramic HEPA filters as opposed the glass-fiber filters that are used in a different area of the total filter assembly. These



(note: final design diameter is 41 mm, not 36 mm shown in figure)

Figure 2. Filter Array Configuration

ceramic filters have a cylindrical shape. One end of the filter is adhered to a stainless steel base plate over a punch flare while the other end is capped. Because the filter is capped, the air will flow through it in the filtration process. Additionally, these ceramic filters can handle high-heat applications, which is why they are going to be used for these units.^[3] However, as a ceramic, these filters are brittle and must be handled appropriately to avoid damaging them. Additionally, the 3M “Fire Barrier Water Tight Sealant” that we will use is also rated for high heat application.^[4] This entire filter system will be capable of handling temperatures up to 1800 degrees Fahrenheit.^[2]

This filter array that is currently in the design process at the LLNL is unlike any other filter system. This filter is designed to withstand extremely high heat and flames, and will have a longer lifespan and greater durability. Though this does not have a direct effect on a repair tool, it is important to understand the use of the product in order to design a tool that will satisfy all requirements.

The LLNL has developed its own proprietary method for manufacturing these ceramic filters. They are 275mm long and will be in a configuration similar to the one seen in Figure 2. Currently, these filters are about 1/4 inch thick. However, as the LLNL refines their manufacturing process, they expect the thickness to decrease to 1/8 inch thick. This is important to note because it will significantly reduce the strength of the filter.

It is also important to understand how these filters will function. The end of the filter opposite the punch flare will be capped and sealed using the 3M sealant mentioned above. The air that is going to be filtered is forced into the tube and out of the punch flare in this filtration process. The direction of airflow can be better seen in Figure 3.

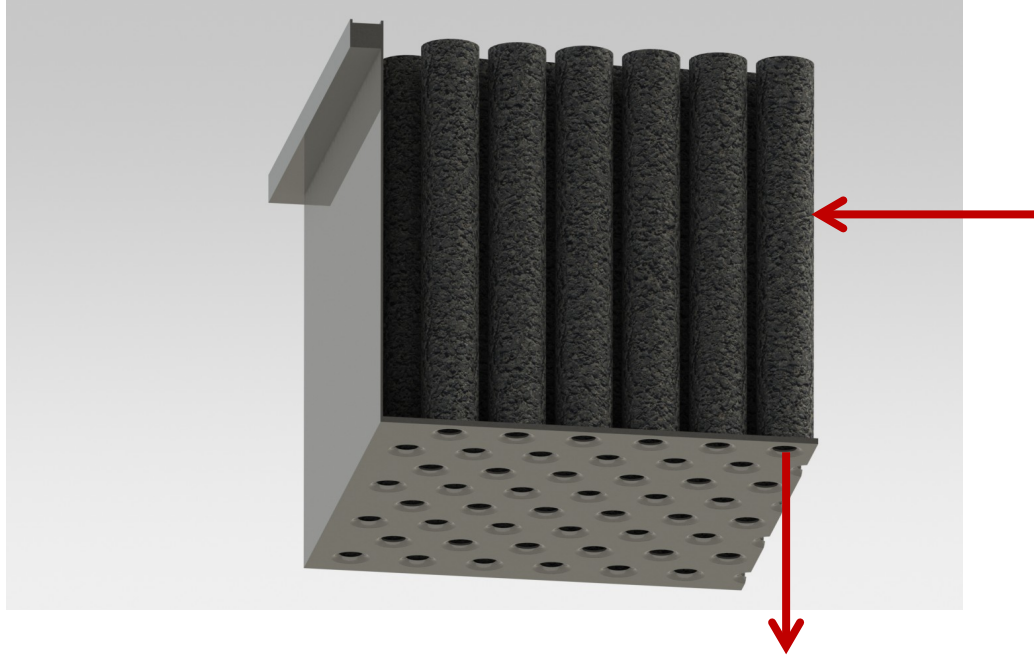

Figure 3. Filter assembly cutaway showing airflow movement

3. Preliminary Design Development

3.1. Preliminary Analysis

The primary goal of this project is to design, build, and test a tool that can be used to remove and replace individual HEPA filter tubes in an array of filters. These tools cannot use any technique that will produce a flame, and it must not damage surrounding filters in any way.^[1]

In order to gain a better understanding of how this goal will be accomplished, the plan is to make a test unit that is similar to actual filter units as a subtask. This will give a better understanding of what it will take to remove these filters. A model like this will require the following: Ceramic filter tubes, sheet metal backing, punch flare tool, basal wood, and 3M Fire Barrier Sealant. A hole was drilled in the sheet metal and flared using a punch flare tool, as seen in Figure 4. Then, the ceramic filter was placed over the hole and stabilized while the base was flooded with 3M Fire Barrier Sealant. A single filter element can be seen in Figure 5.



Figure 4. Punch Flare

An unfortunate part of the 3M sealant used in these tests is that it has an excessively long cure time of about 2 weeks. This makes it difficult to perform multiple successive tests as we are limited by our supplies. This is discussed further in Section 3.1.1.



Figure 5. Single Filter Test Element

3.1.1. Sealant Cutting and Tube Pulling

One aspect that needs to be determined early on is how difficult it is to remove these filter tubes. Though this is an obvious necessity, exactly how difficult it is to remove these filter elements will have a substantial impact on the final design. Analyzing the strength of the 3M adhesive will have a big impact on whether or not the filter elements must be cut out or if they can just be pulled out.



Figure 6. Linear Force Gages in Test Positions

By linear force gauges to apply axial and torsional loads as shown in Figure 6, it will be possible to determine how much pulling force and twisting torque is required to remove a single filter. We quickly found that the 3M sealant would need to be cut somewhere around the filter prior to removal as the ceramic filter could not withstand the loads required to remove it without first cutting sealant. Additionally, if the sealant isn't cut before filter removal, the sealant may peel up and interfere with surrounding filters. Though we did not directly test this by loading the filter to failure, engineering judgment was used to hypothesize this result. After cutting through the sealant within 1mm of the base of the tube, it was then possible to apply forces to the tube with a linear force gauge. The results are summarized in Table 2.

Table 2. Summary of Applied Loads

Direction of Load	Load Magnitude
Axial	40 lbs
Torsional	10 ft-lbs

3.1.2. Filter Cutting and Grinding Test

An alternative to pulling the tubes out of the sealant is to cut them at their base and use a wire brush or circular cutter to remove the excess. This process involves inserting a powered cutting wheel through the punch flare of the tubes and cutting the tube about 1/8 inches above the base. In order to assess the feasibility of this idea, we used a low cost 3/4 inch diamond coated cutting wheel to cut the lower 1/8 inch off of a filter, as seen in Figure 7. The cutting wheel performed extremely well at cutting through the ceramic material, but the



Figure 7. Diamond coated cutting wheel in position

diamond cutting surface did start to wear quickly. Though we thought that it would be possible to find higher quality cutting wheels that would perform better than the cheap one, we were unable to do so. Table 3 summarizes the performance of the various cutting wheels tested. To remove a single filter using the highest performance cutting wheel, it could cost

up to \$150 and would take minutes because of the slow cutting speed and lengthy time required to switch cutting wheels. Ultimately, it was decided that using these cutting wheels would be impractical because it is slow, expensive, and relatively ineffective.

Table 3. Summary of cutting wheel results

Cutting Wheel Type	Cutting Wheel Cost	Result
Diamond, Low Quality	\$5	Lasted 10 seconds
Diamond, Medium Quality	\$11	Lasted 10 seconds
Diamond, High Quality	\$29	Lasted 30 seconds, ¼ of the tube
Ceramic	\$20	Lasted <5 Seconds



Figure 8. Wire brush in position

After the tube has been cut, the next thing to consider is how to remove the remaining 1/8 inches of filter material and sealant. To achieve this task we tested a standard 2 inch wire brush along with a power drill as seen in Figure 8. Using a low speed setting and applying a large amount of pressure, the wire brush removed the filter material at a rate of approximately 1/8 of an inch per fifty seconds. During the test, the brush wandered back and forth along the filter material, making it slightly difficult to hold the drill steady in one place. Higher pressures minimized the movement, but the movement was never fully corrected. A method for stabilization is discussed in the concepts below. The wire brush performed extremely well at removing the 3M sealant in seconds. In addition, the wire brush cleaned a 2 inch diameter groove on the base plate that will be ideal for replacing the sealant when a new tube is inserted. Because of this, use of a wire brush is a practical idea that is worth pursuing.



Figure 11. Remaining filter section



Figure 10. Wire brush in action



Figure 9. Result from wire brush

In order to deal with the issue with the wire brush walking along the filter, we used a small piece of steel tubing as a guide for the brush as seen in Figure 11. As discussed below, this is a more realistic scenario that will be seen in our final design. The wire brush performed exceedingly well at cleaning up the excess filter material and grinding away the sealant. The final result can be seen in Figure 9.

3.2. Discussion of Preliminary Concepts

The following sections discuss concepts involved in the two processes discussed above. Section 3.2.1 involves the sealant cutting and filter pulling method and Section 3.2.2 involves the filter cutting and grinding method.

3.2.1. Sealant Cutting and Filter Pulling Concepts

The following are the two specific operations that need to take place during this process for repairing these HEPA filters: sealant cutting and removing the filter. By using a different tool for each operation, each tool's design will be much simpler.

The first operation to consider involves cutting the sealant. As we discovered in our test, it is imperative that the 3M Fire Barrier Sealant is cut prior to filter removal. There were two primary concepts that were developed for this process: one that cuts sealant from the punch flare side, and one that cuts it from the filter side.

The concept that cuts from the punch flare side can be seen in Figure 12 below. In this design, the plunger is inserted into the punch flare and the blades would fold in to allow it to pass through. Once the blades pass through the punch flare, they would spring outwards and into the interface between the filter and the punch flare. Then, the user would rotate the plunger, cutting the sealant under the filter and allowing it to be removed. A drawback to this

design is that it would not cut the sealant around the filter, but rather just the sealant underneath it. This would open up the possibility for the sealant to peel up, interfering with the surrounding filters. Additionally, because this design relies on a spring-like action to extend the blades, wear could be an issue.

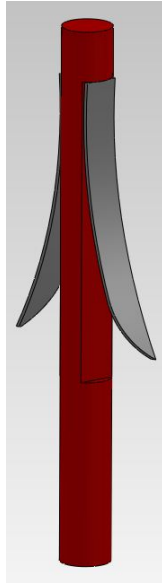

Figure 12. Cutting Concept 1

The second concept developed to cut the sealant can be seen in Figure 13. This tool cuts the sealant from the tube side. The use of this tool is simple and will require little user skill. The cutting tool will be placed over the tube that is to be removed. Because the tube is being removed and damage to the tube is a non-issue, a tight clearance between the tool and filter will ensure that sealant closest to the filter is cut. Once the sealant cutter has been placed over the filter, the handle will allow for a twisting motion that will assist in the cutting of the sealant. One possible drawback to this design is that it would not cut any sealant that is directly below the filter. This would mean the filter would still need to be pulled axially or torsionally in some way which was deemed impractical.

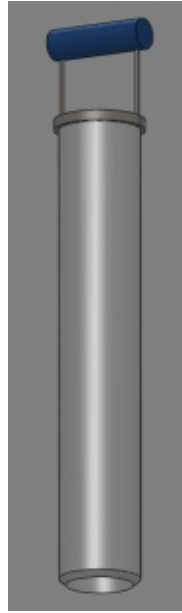

Figure 13. Cutting concept 2

The second operation to consider involves removing the filter. After the sealant has been cut, there needs to be an easy way to pull the filter out from the array without damaging the surrounding filters. We have decided on two main removal techniques. The first requires the user to remove the entire tube by twisting, pulling, or a combination of both. This technique is still being tested as mentioned in Section 3.1.1.

An extremely rough design of a tool for this technique can be seen in Figure 14. This design uses rubber cleats that will swivel upward when the tool is inserted into the center of the filter to allow for easy installation. This means that cap over the end of the filter would first need to be cut off. The cleats will also be prevented from rotation downward after a certain point. This will allow for the cleats to grip the inside of the tube allowing the user to pull the tube upward with enough force to remove the filter from the sealant. This design also has a sealant cutter located at the bottom of the tool that would cut the sealant along the punch flare, as well as between the base plate and filter tube. This type of cutting mechanism is complex and would require a lot of engineering consideration. Additionally, if a tube is broken or damaged, it may be impractical to pull on it in any way at all.

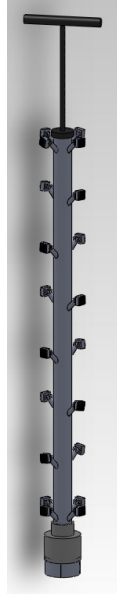

Figure 14. Pulling Concept 1

Another concept for pulling out a filter is seen in Figure 15. This concept uses two concentric tubes with a pivot point at the inner tube. The three arms would grab the outside of the filter and clamp down on it when the handle at the top is pulled. This would then make it possible to pull or twist the filter out of the sealant. This design is good because the force exerted by the arms increases as the handle is pulled more. However, this could be a problem if an excessive amount of force is applied causing damage to the filters. This is especially a concern considering that the filters may become thinner as the manufacturing process improves. Also, if the filters are broken, this tool would be difficult or impossible to use because it partially relies on complete tube.

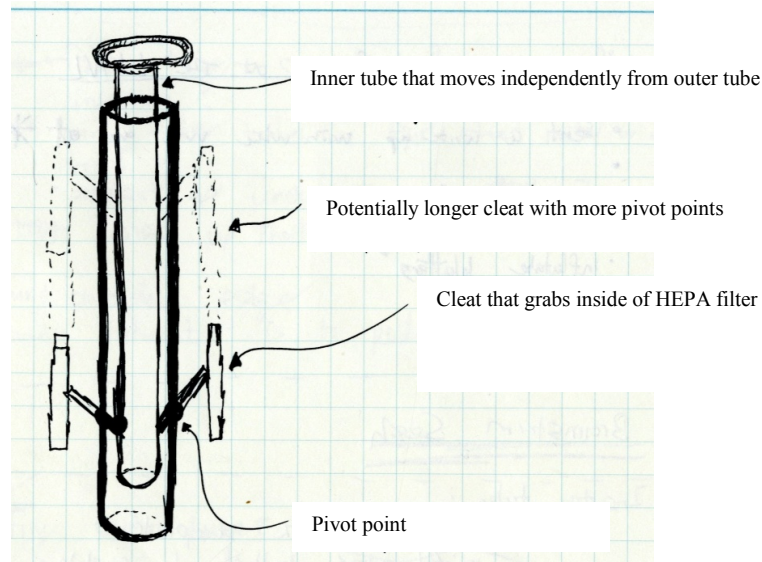

Figure 15. Pulling Concept 2

3.2.2. Multi-Purpose Concept

The following concepts can be used for multiple operations. Some of the concepts are capable of performing all of the design tasks, while some of the concepts are interchangeable with one another.

The concept seen below in Figure 16 can be used for multiple operations. After the filter tube has been cut, the user would place the main guide pin into the punch flare of the filter location that is being serviced. The three smaller guide pins would be inserted into the punch flares of the surrounding filters. The three support pins would prevent the tool from rotating allowing for greater stability. Once the guide pin has been installed, a cylindrical and hollow wire brush tool would be placed over the guide pin allowing for a stable and precise removal of the remaining 1/8 inch filter and sealant. The guide pin would also be used to install the new filter.

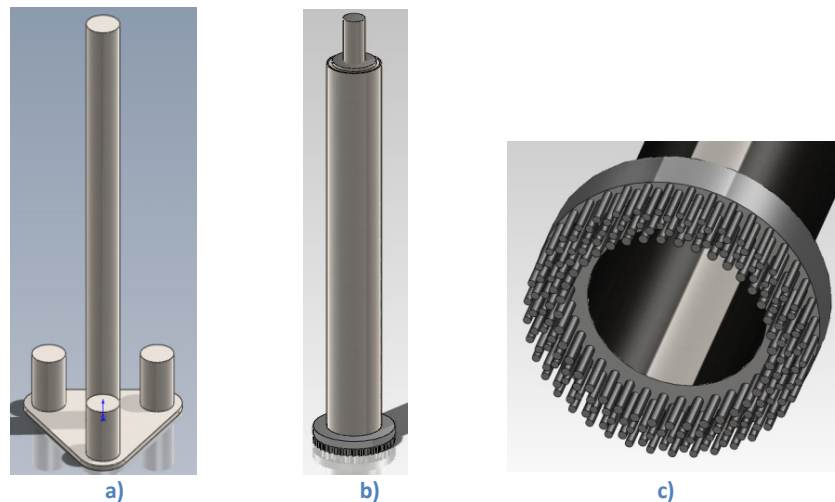

Figure 16. Multi-Purpose Tool Concepts 1

Another method to support a filter can be seen in Figure 17. This tool supports the filter from the filter side as opposed to the punch flare side. This tool works by supporting the desired filter by bracing off of the surrounding filters. This tool could be used for the installation of a new tube, as well as a support while the newly applied sealant dries.

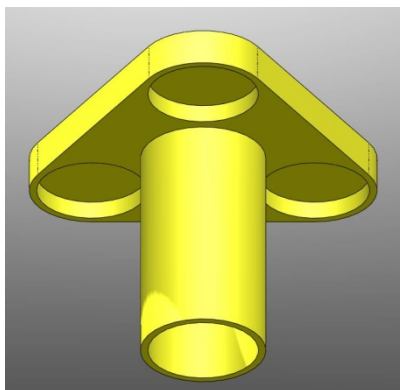

Figure 17. Multipurpose (Inserting and support) Tool Concept 2

Another tool used for supporting a filter during insertion can be seen in Figure 19. This part could be used to support the filters when they are inserted as well as give support to other tooling involved in the processes. For example, in Figure 18, this tool is seen in a cutaway view showing how it could potentially support a grinding brush.

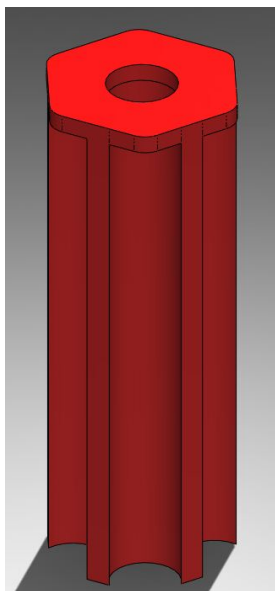

Figure 19. Inserting Tool Concept 3

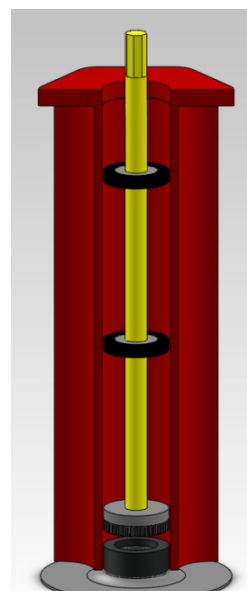

Figure 18. Inserting Tool Concept 3 Cutaway with Grinder

Additionally, from our experience with the 3M sealant, we found that it was difficult to apply without getting sealant on the outside of the filters. Because of this, it would be useful to have a disposable sealant applicator, as seen in Figure 20. Sealant would be inserted into the center of this applicator from a caulking gun and would flow through the veins and into the area in which the new filter will be set. This tool can be seen in position in Figure 21.

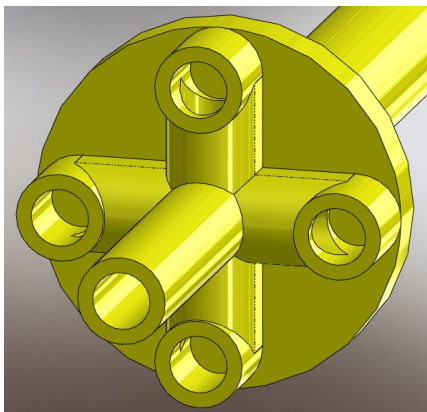

Figure 21. Sealant Applicator

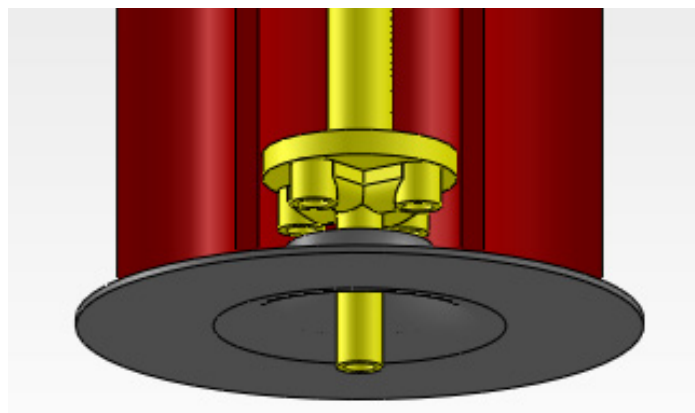

Figure 20. Sealant Applicator in Position

Another concept we developed involves supporting tools off the enclosure surrounding the filters, as seen in Figure 22. This concept allows the user to anchor the tool onto the frame allowing for mobility and stability. The tool's mobility is achieved by using guide rails and sliders to move the tool in two dimensions. Once the tool has been moved to the desired location, the guide rails would be put under tension allowing for greater stability and stiffness. The next step would be to place a steel guide tube around the filter. The bottom of this tube would have a sharp surface that would cut into the sealant and rest on the base plate. This will be achieved by tightening the tube onto four guide pins with fasteners. With the steel guide tube locked into place, this tool would allow for the filter element to be removed through any of the methods previously mentioned. This tube would also work with the sealant injector and other devices mentioned above. This is a favorable design because it uses surrounding filter housing as a brace rather than the delicate surrounding filters.

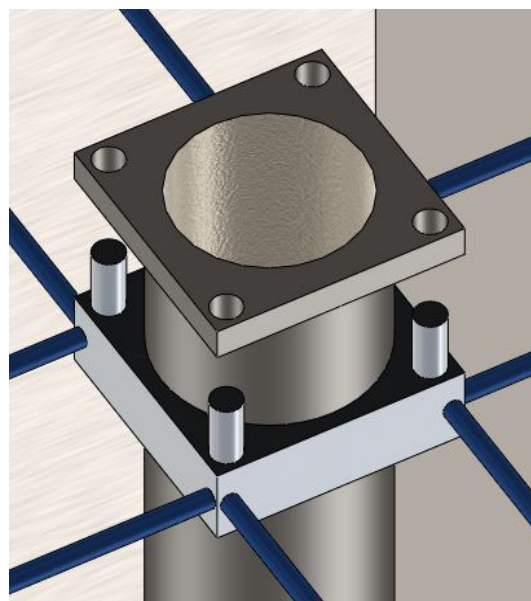
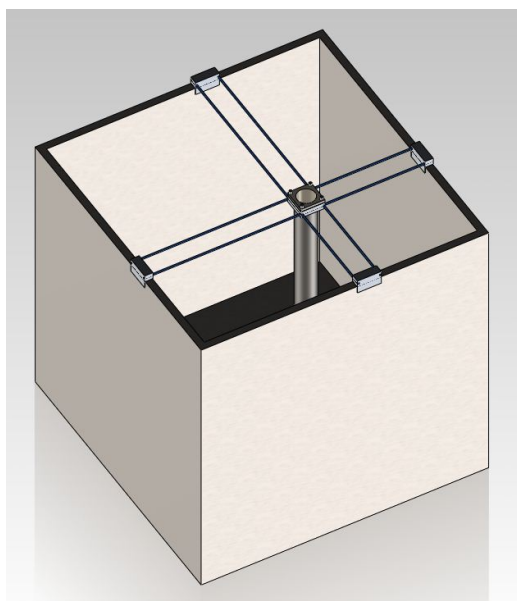

Figure 22. Tooling to brace off of filter box

3.3. Concept Decision

Because the tool seen in Figure 22 has the advantages listed above, we have decided to pursue this as a final design. This tooling will provide the necessary support and protection for the other processes involved in removing a single filter element. This is the only design that doesn't use the surrounding filters as support, thus making it the most desirable because it is the least likely to damage surrounding filter elements. This design is explained in more detail in the following section.

Additionally, it was decided that pulling filter elements out of the sealant was an impractical idea because they break free in a violent matter that is unsuitable for real use. Also, as mentioned above, using cutting wheels on the filter elements is impractical because of the cost, time, and ineffectiveness associated with this process. We ultimately decided that an automatic center punch can be used to break these filters free. This is discussed in more detail in the following section.

4. Final Design Concept

The final design concept can be seen in Figure 23 and is largely based on the tool and filter supporting concept in Figure 2. After serious design considerations we found that this concept provided a platform that would allow us to reach all of our design specifications set forth in Table 1. Major advantages of the final design concept are as follows: the tool is able to reach every filter element within the array, the tools design allows for the removal of a single filter element without coming into contact with any filter in the array that is not being removed, reducing the possibility of damaging surrounding filters, and the tool requires minimal user skill with simple to follow instructions. The designs in this section are the first revision of our final design.

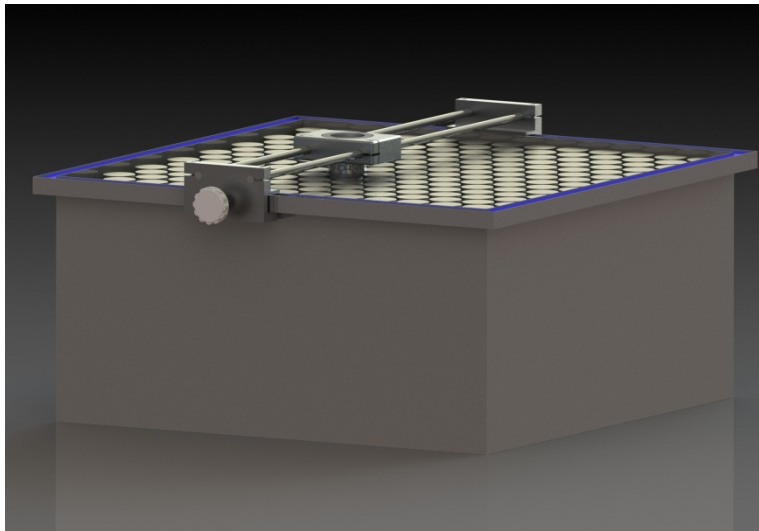

Figure 23. Final Tooling Support Design Concept

4.1. Clip Design

While designing the clips used to secure the tool to the filter housing assembly, and to provide lateral movement to the desired column where the filter element is to be removed, we wanted to produce clips that were cheap, easy to produce, and did not require complex assembly. The main clip seen in Figures 24 and 25 will be used to secure the tool to the filter housing. This will be achieved by turning a knob (5) which in turn pushes a plate (2) against the filter housing. As the knob is turned, a threaded push shaft (3) that is secured to the knob along with female threads in the clip provides tension to the clips, securing them to the filter housing. The purpose of this is to provide rigidity to the tool system, and to prevent lateral movement. This locks the tool in the desired location. The knob and shaft are secured to the push plate by a snap ring (4). This will allow the knob and push shaft to rotate while the push plate remains horizontal. The two clips are attached by two 3/8" diameter hardened precision 440C stainless steel shaft. These shafts provide outstanding rigidity and strength to the tool. By selecting these shafts, we have eliminated any significant deflection or sagging of the tool. This prevents the tool from contacting and damaging filter elements. The shafts are

secured to the clips by creating an interference fit when two black-oxide alloy steel socket head cap screws, 10-24 thread, 3/4" length are used to tighten the clips onto the shafts. By using this method to secure the shafts to the clips, we have made assembly and disassembly easy and effective.

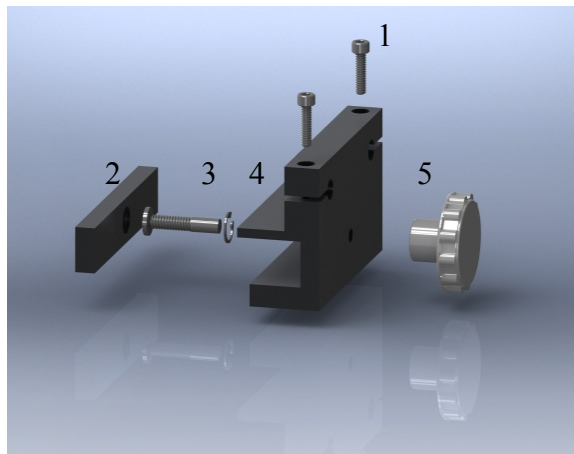

Figure 24. Main Tensioning Clip

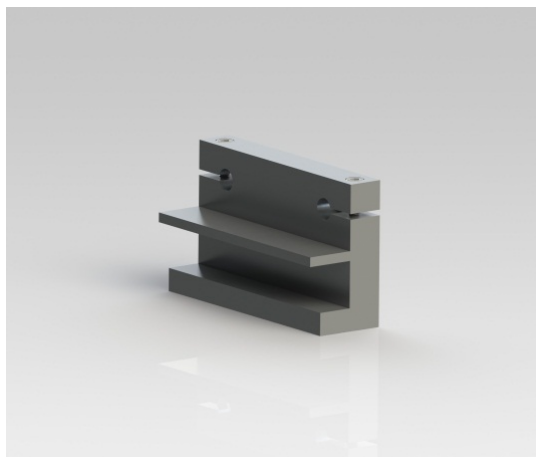

Figure 25. Secondary Clip

4.2. Slider Design

The slider portion, seen in Figure 26, of the tool allows the tool to be maneuvered forward and aft to the desired filter element where servicing is required. Once again, our main objectives when designing this part of the tool, was to design a part that easy to manufacture, and easy to use. The slider will ride along the shafts allowing the user to locate the filter element with easy. Once the slider has been maneuvered to the desired location, the user will lock the tool into place by tightening two black-oxide alloy steel socket head cap screws. This locking mechanism is identical to the one used to lock the clips onto the shafts. The slider will use two linear slider bearings to ride along the rails. These bearings are

discussed in detail in the next section. The slider also provides a stable platform for the insertion and securing of the protective tube that will also be discussed later in detail.

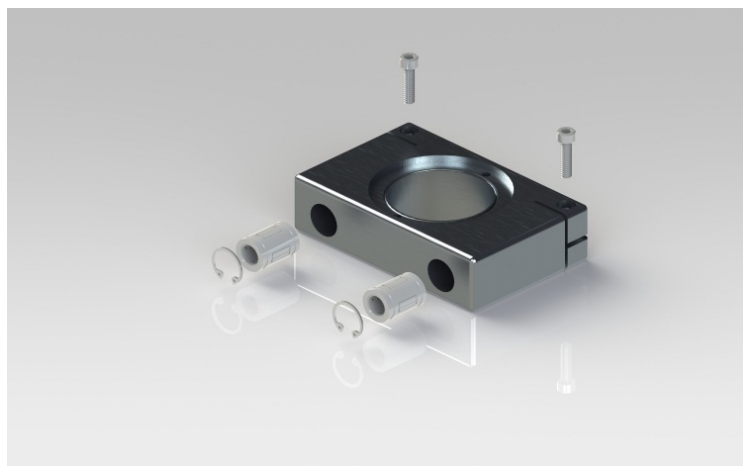

Figure 26. Slider

4.2.1. Bearings

In order to facilitate easy sliding along the stainless steel rods, linear slider bearing were integrated into the main slider component. These bearing, seen in Figure 27, are capable of supporting a dynamic load up to 100 lbs. which far exceeds the forces we will every apply to these bearings. These bearing a held into place via a retaining ring that is positioned after the bearings are inserted into the slider bore. These bearings were suggested by the manufacture for the particular shafts we are using because they are strong and resistant to failure.

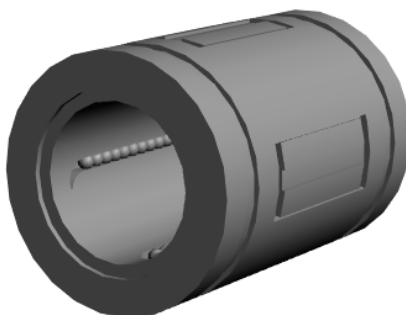

Figure 27. Linear Slider Bearings, McMaster
P/N 6489K62

4.3. Steel Protective Guide Tube

The steel protective/guide tube, seen in Figure 28, has been designed primarily as a way to isolate the filter element where servicing is required. In addition it will provide a guide for the tools user to perform the required maintenance. Once the slider has been locked into place, the user will insert the tube around the desired filter element. The bottom of the tube

will have a sharp edge that will allow the tube to cut through the sealant below. Once the tube has been pressed through the sealant, and is resting on the stainless steel base, the user will secure it to the slider with two black-oxide alloy steel socket head cap screws. This will provide a stable platform for the user to operate the maintenance, as well as provide more rigidity to the tooling system. With the tube in place the user can begin to operate on the filter element without damaging any of the surrounding filters.

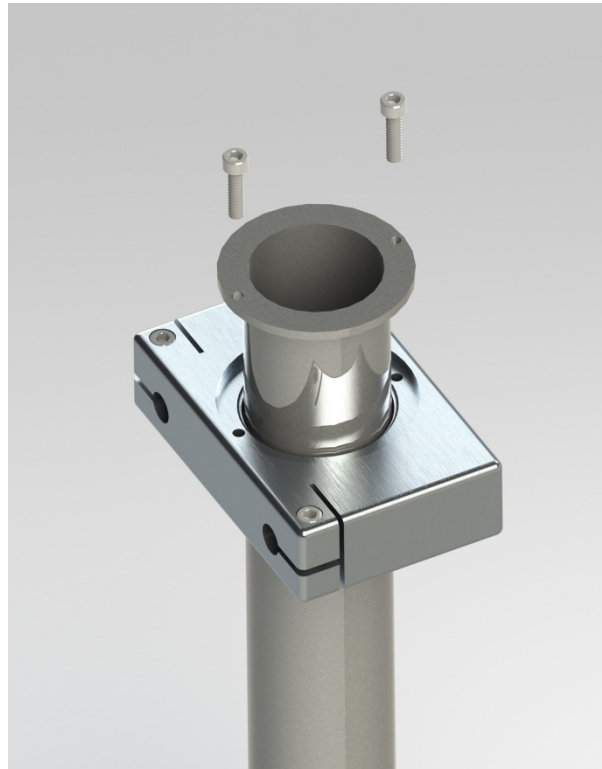

Figure 28. Steel Protective/Guide Tube and Slider

4.4. Filter Removal

In section 3.1.2, we discussed how cutting the filter elements with a 7/8" diamond coated cutting wheels were ineffective, and expensive. We needed to find a better way to remove the filter elements quickly, and cheaply. After much deliberation, we were able to find a method that far exceeded our expectations. To remove the filter elements, we would use a common everyday automatic center punch as seen in Figure 29. This method works extremely well, and can be used for the life of the tool. To remove the filter element, the center punch is placed on the inside walls of the filter element, accessed through the punch flare. The user applies pressure onto the filter until the tool pops. This should be done twice in one location, then rotating 180° and repeating. By using this method, as opposed to cutting, the remaining filter material is mostly broken up and brittle. This provides an excellent condition for the use of a wire brush to remove the remaining material and sealant. Although we did not encounter a situation where the tool the broke violently through the filter material during testing, the steel protective/guide tube will contain any possibility of damaging the surrounding elements by using this method. The result of using the automatic punch can be seen in Figure 30.



Figure 29. Automatic Center Punch in Position



Figure 30. Result from Automatic Punch Use

4.5. Grinding Excess

After the filter is removed using an automatic punch, parts of the filter and sealant still remain. In order to remove the residual filter and sealant, a wire cup brush on a 12 inch extension is attached to a power drill and inserted into the steel protective sleeve and lowered to the base of the filter. When spinning, this brush cleans up residual material and leaves a clean area for fresh sealant to be injected and a new filter to be placed.

4.6. Protective Sleeve

A protective sleeve can be used to protect a new filter when it is inserted into the protective tube. This sleeve will wrap around a filter when the filter is inserted and will prevent any sealant from getting on the sides of the newly inserted filter when the protective tube is removed. These protective sleeves can be seen in Figure 31.



Figure 31. Protective Sleeves

4.7. Sealant Injector

As mentioned in the early concepts, a sealant applicator can be used inject sealant into the appropriate location. As shown in the concepts, this design was bulky because it had exposed passages in which the sealant could flow through. This design involved into something simpler, seen in Figure 32. This is our first printed prototype of the sealant injector. This disposable applicator was manufactured using the Eden rapid prototyping machine. The sealant passages are recessed into the part, making the part easier to manufacture. Additionally, a small recessed ring was added to the bottom of the application. This provides a guide that aligns the applicator onto the punch flare. In the next iteration of this design, the bottom tube, which extends through the punch flare and serves as the sealant injection location, will be designed to interface with a syringe. This will allow easy application of a predetermined amount of sealant through the applicator



Figure 32. Sealant Injector

5. Final Design Prototype

Before machining the parts, we decided that it would be beneficial to use the rapid prototyping machine to print all of our parts. This allowed us to quickly discover where problems may arise while saving cost and time.

5.1. Clips

Figure 33 shows the clips that were printed using the rapid prototyping machine. We were satisfied with how these rapid prototyped clips performed and did not feel that any changes were needed.

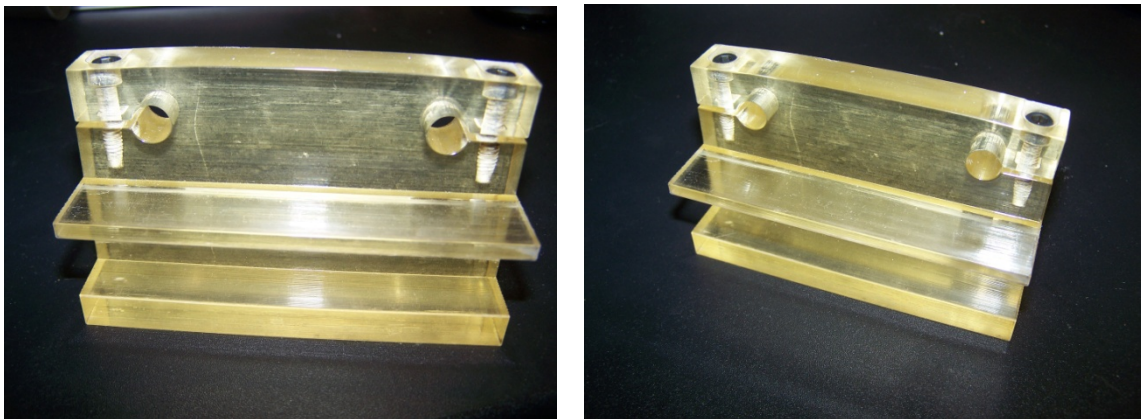

Figure 33. Rapid Prototyped Clips

5.2. Slider

Below, Figure 34 shows slider that was printed on the rapid prototyping machine. From this design, we found that there were several areas that required modifications before machining this part. For one, the diameter of the hole for the protective tube was excessively big. This extra room allows the protective tube to enter at an angle which could then allow the protective tube to crash into surrounding filters. The 6 to 7mm gap between the filters increases the risk of hitting filters if the slider hole is too big.

The different between the diameter of the protective tube and the slider hole on this prototype was 1.8.” By decreasing the diameter to 1.76,” it could be ensured that the protective tube would not be able to contact surrounding filters due to wobble when inserted into the slider.

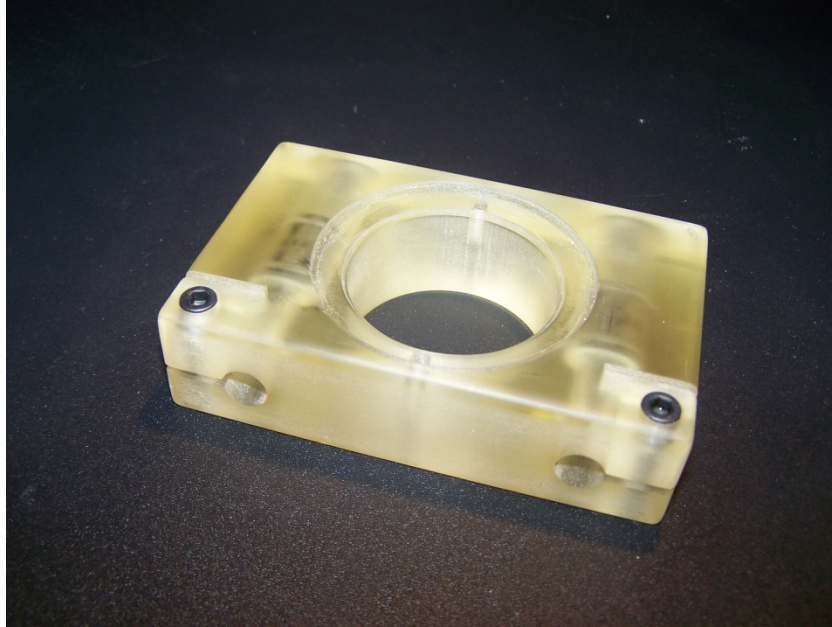

Figure 34. Rapid Prototyped Slider

Additionally, the rapid prototype allowed us to see that we made the shaft holes too big. This then made it impossible to lock the slider into place because the excessively big gap of 0.010” between the shaft and the slider. The EDEN rapid prototyping material is not as stiff as aluminum so it was possible to lock the printed slider onto the shafts; however, the deflection of the slider when locked down was excessive and it was deemed that this would not be possible with the machined aluminum slider.

5.3.Sealant Injector

The sealant injector is a part this is impossible to machine because of the interior geometry. Printing the injectors is an economical way to create this device. In the first prototype, there was a groove to align the injector over a punch flare. We found that this groove insufficiently aligned the injector over the punch flare. Instead, we implemented a protruding step instead of a groove. This more effectively aligns the injector over the punch flare.

Another change made to this part was this incorporation of a Luer Taper^[5] into the sealant injector. The Luer Taper is a standard interface between syringes and needles and is thus a practical way to interface the sealant injector with a syringe that contains a predetermined amount of sealant. This Luer Taper can be seen in Figure 35.



Figure 35. Revision 2 of the Sealant Injector with a Luer Taper

From this prototype, we found one problem: the tip of the Luer Taper was too thin. This made the taper weaker and more susceptible to damage if the sealant injector is over tightened on the syringe.

5.4. Pusher Shaft

In the first rapid prototyped design of the pusher shaft, we ignorantly made the mistake of not continuing the threads to the end of the shaft. This made it impossible to thread the pusher shaft into the clip because of the lack of threads on the end. Fortunately, we were able to use a die to continue the threads so that we could still use the shaft for testing.

5.5. Knob

In the first knob we used utilized a set screw to tighten the knob onto the pusher shaft. This, however, did not work out as well because we had to continue the threads to the end of the pusher shaft so the set screw was screwed into threads. This is not idea and did not provide a solid interface between the knob and the pusher shaft.

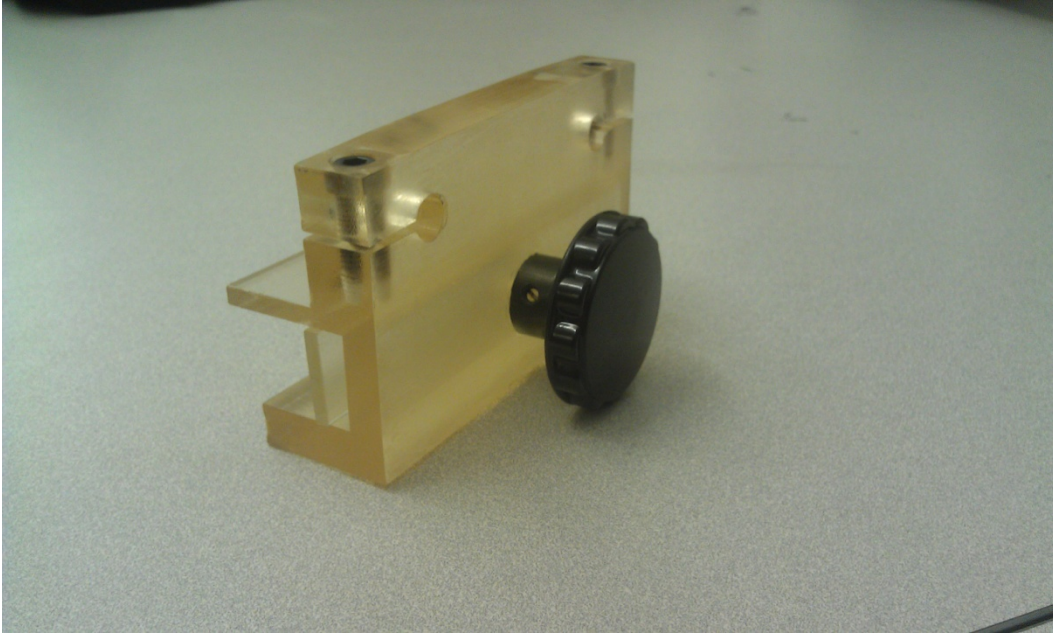

Figure 36. Knob on the Rapid Prototyped Slider

The knob we originally used can be seen in position on the rapid prototyped clip in Figure 36. The set screw that holds the knob onto the pusher shaft can be seen in Figure 36 as well.

6. Final Design

Below are all of the components of our final design that will be given to the Lawrence Livermore National Laboratory and demoed at the Senior Project Expo on May 31, 2012.

6.1. Clips

The clips remained relatively unchanged from the rapid prototyped design to the machined design. The CNC machined clips can be seen in Figure 37.



Figure 37. Machined Clips

6.2. Pusher Shaft

The pusher shaft is a $\frac{1}{4}$ -20 threaded rod with a 0.5 inch diameter step that is on the pusher plate side of the pusher shaft. The pusher shaft is inserted through the clip and provides an interface between the knob and the pusher plate.

6.3. Knob

The knob, seen in Figure 38, is attached to the pusher shaft. The knob has a female thread which allows it to simply be screwed on to the pusher shaft. The knob is then fixed to the shaft via loctite so that it cannot back off of the pusher shaft.



Figure 38. Knob

6.4. Pusher Plate

The pusher plate with the pusher shaft attached can be seen in Figure 39 and is a simple plate with hole with a snap ring groove inside of the hole on one of the sides. The step on the pusher shaft is inserted into this hole and the snap ring then holds the pusher shaft into place on the pusher plate. This allows the pusher shaft to spin independently of the pusher plate.



Figure 39. Pusher Plate and Pusher Shaft Assembly

6.5. Shafts

Two 3/8" diameter hardened precision 440C stainless steel shafts are used to connect the two clips and provide the rails on which the slider moves. We have two lengths of these

shafts: one set for a 1 square foot box and another set for a 2 square foot box. Shafts for the 1 square foot box are shown in Figure 40.



Figure 40. Shafts for a 1 Square Foot Filter Box

6.6.Slider

The slider went through many modifications from the rapid prototyped design to the aluminum design which was CNC machined by a professional machinist. These changes were primarily all made in order to improve machinability of the part. The final slider is shown in Figure 41.

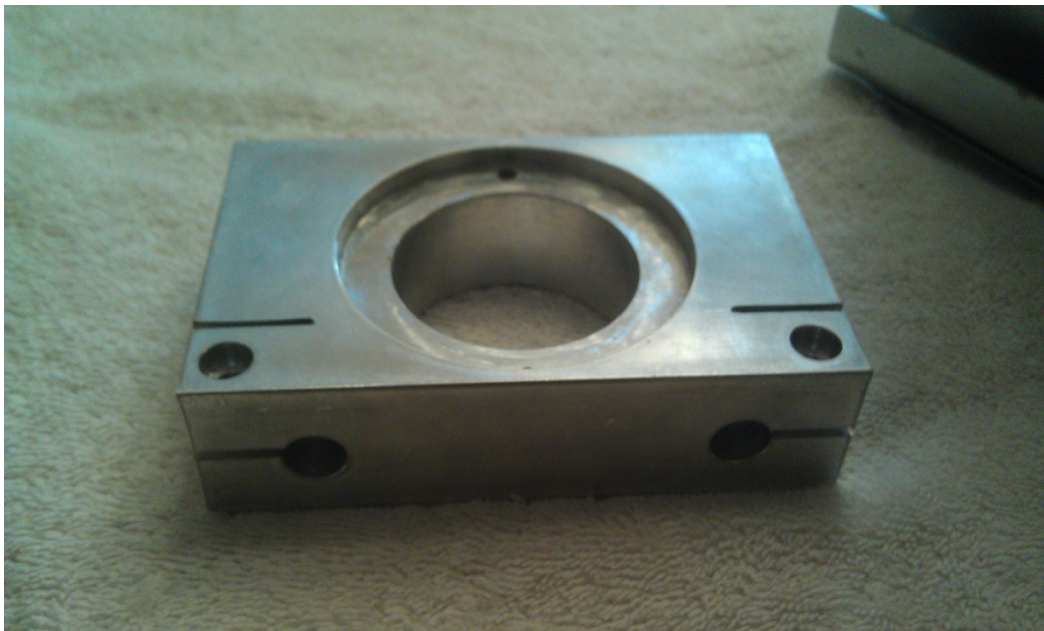

Figure 41. Machined Slider

First, the location of the bearings was shifted from the center of the slider towards the opening of the bearing bore. This change was done because of limitations to the tooling used to make the snap ring groove inside of the bearing bore. The tool used to make this groove is not long enough to reach the center of the slider where it originally was in the rapid prototyped slider. Moving the bearing to the end of the bearing bore made it possible to machine the snap ring groove needed to hold in the bearing.

Another modification we made was also due to limitations to tooling. The slots in the slider parallel to the face of the slider were impossible to machine because there was no tooling of the size we wanted that would work for this piece. Instead, we decided that these slots could be made by running a bandsaw along the path where we wanted to groove. Not only was this quicker, it was also cheaper because we didn't need to order an expensive alternative end mill for this feature.

Another change made was the elimination of the all of the rounded edges on the slider. These rounded edges, though pretty, are time consuming to machine and would have significantly increased machining costs. Because these edges were purely for aesthetics, we decided that they could be eliminated from the machined slider.

The hole in which the protective tube is inserted on the slider had to be resized. On the rapid prototyped parts, we oversized the hole which caused the protective tube to have too much wiggle room which could allow the protective tube to be inserted at an angle and strike surrounding filters. We changed the size of this hole so that it was about 0.010" bigger than the protective tube. This allows for a snug fit between the protective filter and the slider but ensures that there will not be any interference due the sizing errors of the protective tube.

Lastly, the free sliding holes that the shafts go through were resized so that an interference could be achieved when tightening down the slider onto the shafts. Originally, we had a 0.010" clearance between the shafts and the free sliding holes on the slider. The clearance was changed to 0.002" which made it possible to clamp the slider onto the shafts to lock it into place for the filter removal process.

The machined clips still utilize the same linear slider bearings mentioned in Section 4.2.1. These bearings made sliding along the shafts smooth and effortless when the slider is not clamped down.

6.7. Protective Tube

The protective tube, made from 4130 steel, is inserted into the slider to protect the surrounding tubes while the filter removal operation occurs. The flange at the top of the tube, seen in Figure 42, was welded on to the protective tube. This flange provides an

interface between the slider and the protective tube and allows the protective tube to be locked into position via two 10-32 screws that go through the flange and into the slider.



Figure 42. Protective Tube with Flange

6.8. Wire Brush

Figure 43 shows the final wire brush design. A cup brush is attached to an extension, which is then attached to a drill. The extension allows the cup brush to reach the base of the filters when inserted from the opening of the protective tube. When powered, the drill spins the cup brush and cleans out the remaining pieces of the filter and the excess sealant.



Figure 43. Wire Brush with Extension attached to a Drill

6.9. Punch

As mentioned in section 4.4, an automatic punch is used to break apart the filters for removal. The punch we chose is a Starrett Automatic Punch because it has an adjustable stroke that can be tuned to work best for this application. The punch that we will use is shown in Figure 44.



Figure 44. Automatic Punch

6.10. Sealant Injector

After our second revision of the sealant injector prototype discussed in Section 5.3, we made few changes to the final design of this piece. The only significant change we made was that we made the Luer Taper fitting thicker so that it was more durable. From testing, we found that it was easy to strip this fitting if it was over tightened on a syringe. Thickening this fitting reduces the risk of this occurrence. Figure 45 shows the final revision of the sealant injectors. Six of these will be given to the Lawrence Livermore National Laboratory for their use.



Figure 45. Final Sealant Injectors for the LLNL

6.11. Sealant Injector Handle

The sealant injector handle attaches to one end of the sealant injector extension. This handle provides a simple way to hold on to the extension. The handle can be seen in Figure 46.



Figure 46. Sealant Injector Handle

6.12. Sealant Injector Extension

The sealant injector extension is used to bridge the gap between the sealant injector and the sealant injector handle. It is a 12” long threaded rod with 10-32 threads on each end. The length of this rod allows the sealant injector to be extended through the protective tube to the base of the filters. The entire assembly with the sealant injector, the extension, and the handle can be seen in Figure 47.

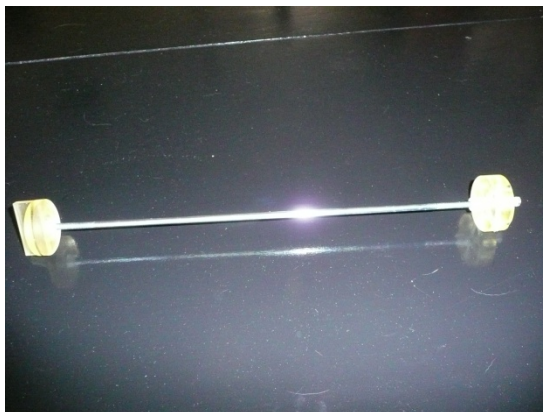

Figure 47. Sealant Injector, Extension, and Handle Assembly

6.13. Protective Tube Riser

In an earlier phase of the project, we considered using protective sleeves, discussed in Section 4.6, to prevent sealant from getting on the sides of new filters when the protective tube is removed. However, we decided that there is not a need for this protective sleeve if no sealant is on the protective tube. Instead of using protective sleeves, our solution is to put a riser under the flange of the protective tube. This will lift the entire protective tube up and

eliminate the chance of the sealant to get on the base of the protective tube when the sealant is injected. This, in turn, eliminates the chance of sealant getting on the sides of the filters when the protective tube is removed. This riser can be seen in Figure 48.



Figure 48. Protective Tube Riser

6.14. Sealant Drying Cap

The sealant drying cap, seen in Figure 49, is used to hold the newly placed filter in position once the tooling has been removed.

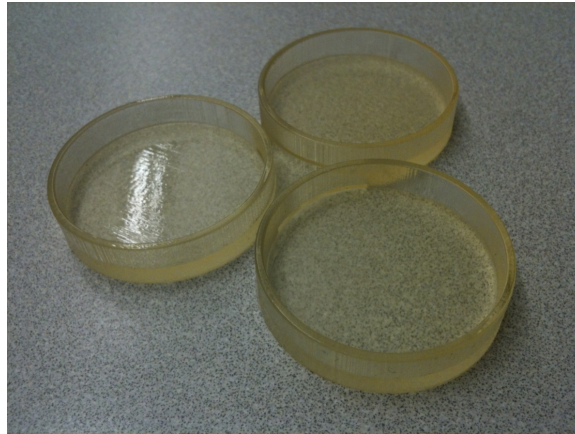

Figure 49. Sealant Drying Cap

7. Operation Procedure

This describes the procedure for using the tooling developed to remove and replace the HEPA Filters.

7.1. Tool placement

7.1.1. Install filter removal tool (FRT) onto filter box.

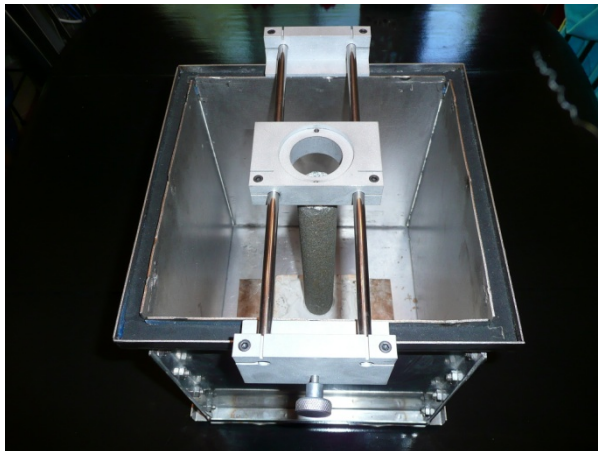

Figure 50. Filter Removal Tool Installed on Filter Box

7.1.2. Slide FRT horizontally left or right to desired location.

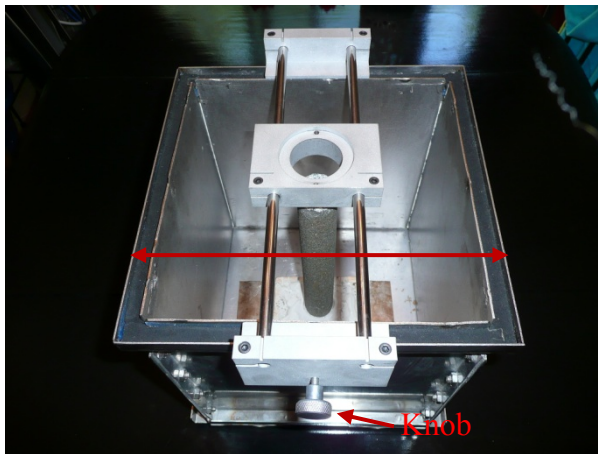

Figure 51. First Direction of Motion for Aligning FRT

7.1.3. Secure horizontal movement by tightening FRT knob, shown in Figure 51.

7.1.4. Move FTR slider fore and aft to desired location. Ensure that the 1.5" hole on the slider is aligned over the filter which you wish to remove, shown in Figure 52.

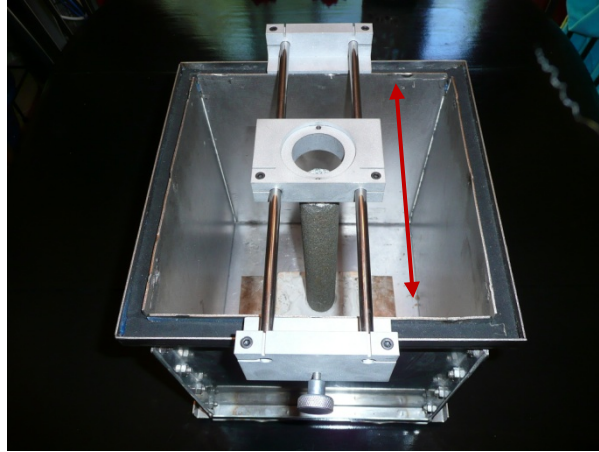

Figure 52. FRT Slider motion in Fore and Aft Direction

7.1.5. Secure FTR slider by tightening the two 10-24 cap screws

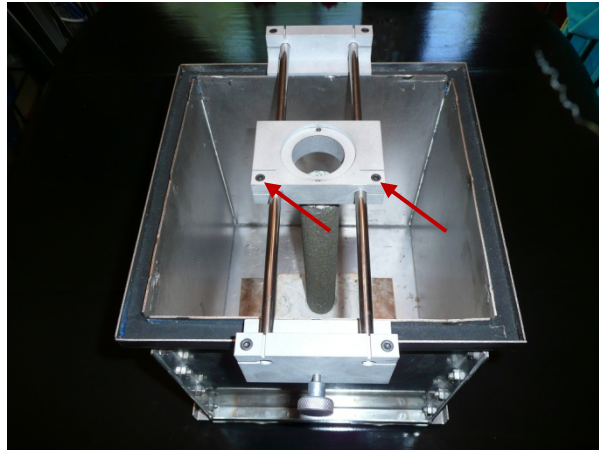

Figure 53. Arrows indicating the two 10-24 cap screws used to secure the Slider

7.1.6. Install protective steel tube over filter and apply pressure to ensure tube has cut through sealant, and is resting on steel plate.

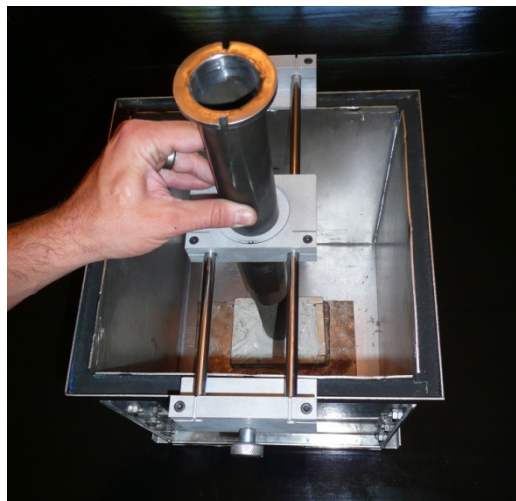

Figure 54. Installing Protective Steel Tube

7.1.7. Secure protective steel tube with two 10-24 cap screws. Be sure to alternate tightening these screws to ensure that the protective tube is evenly seated.

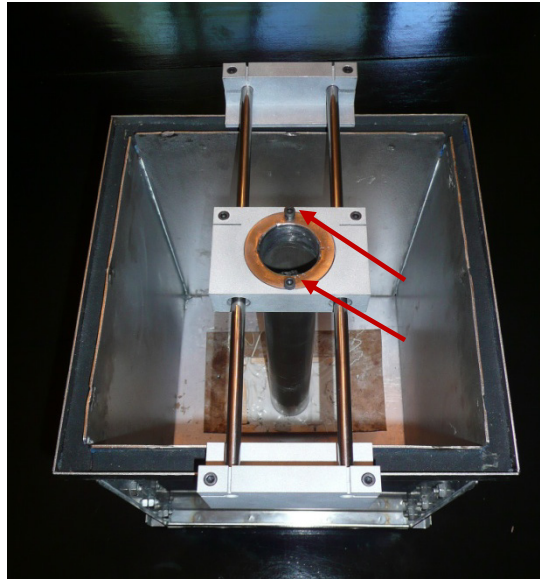

Figure 55. Arrows indicating the two 10-24 cap screws used to secure Protective Steel Tube

7.2. Removal of Filter Element

7.2.1. Through the punch flare, crack filter by placing automatic center punch onto filter just above punch flare and pressing until punch pops. Repeat the following as necessary in multiple locations until the filter can be removed.



Figure 56. Automatic Punch in Position

7.2.2. Remove filter.



Figure 57. Removing the Filter

7.3. Removal of Remaining Filter Material, and Sealant

7.3.1. Once the filter has removed, remove remaining filter material and sealant by placing wire cup brush into protective steel tube. With the use of a hand drill, remove the remaining material. To ensure longevity of base plate, do not apply excessive pressure when removing material.

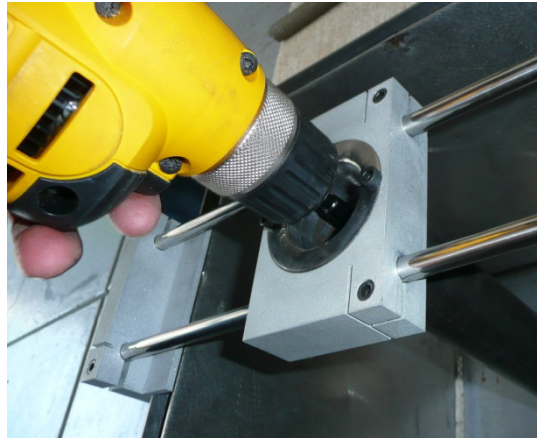

Figure 58. Hand Drill on Extension to Clean Base

7.3.2. Remove debris with shop vac.

7.3.3. Repeat until the base is clean and free of debris.

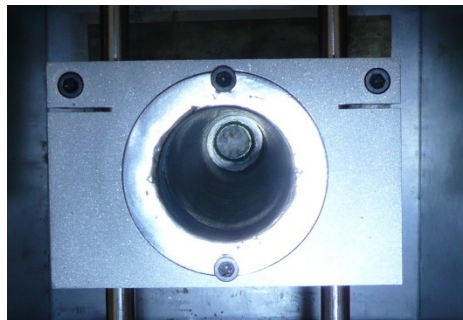

Figure 59. Clean Base

7.4. Applying New Sealant

7.4.1. Unscrew protective steel tubing cap screws.

7.4.2. Raise protective steel tubing and install protective tube riser.

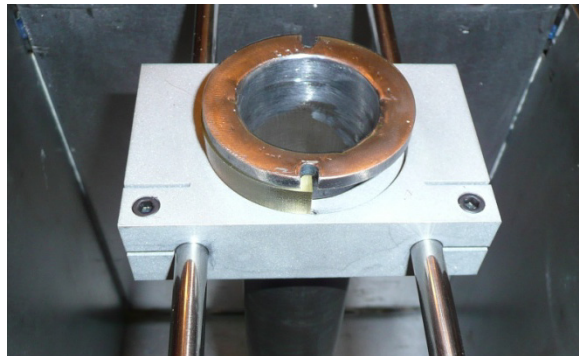

Figure 60. Protective Tube Riser Installed

7.4.3. Install disposable sealant injector onto sealant installation tool.

7.4.4. Place sealant injector assembly into protective steel tube. The sealant injector has been designed so that the injector sets on and in the punch flare.



Figure 61. Installing sealant injector assembly

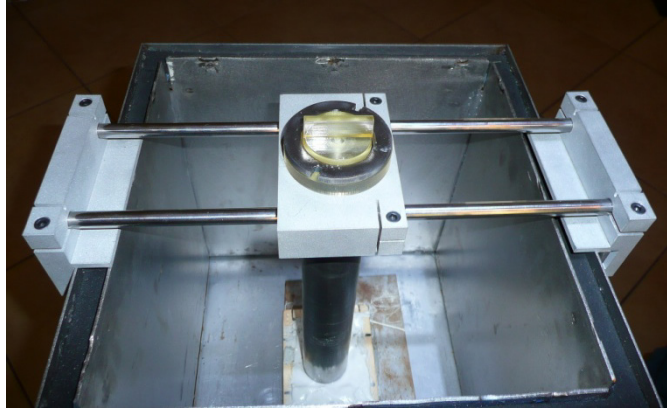

Figure 62. Sealant Injector Assembly in Place



Figure 63. Sealant Injector Protruding from Punch Flare

7.4.5. Fill a syringe with approximately 8 cubic centimeters of sealant.

7.4.6. Attach sealant filled syringe to the sealant injector.

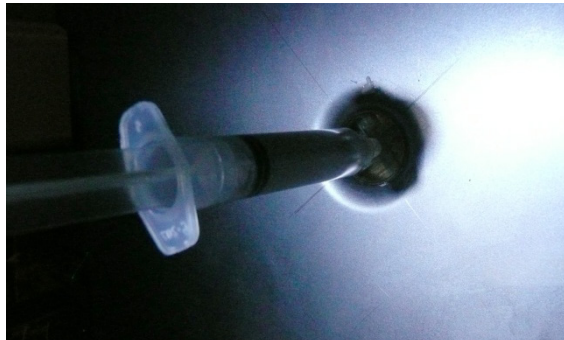

Figure 64. Sealant Filled Syringe attached to Sealant Injector

7.4.7. Depress the syringe to inject sealant. Remove the syringe and dispose of it.

7.4.8. Remove sealant injector assembly. Dispose of the sealant injector.

7.5. Install New Filter Element

7.5.1. Install new filter in the sealant by placing it in the protective steel tube and over the punch flare. Gently lower it onto the base.



Figure 65. Lower New Filter into Position

7.6. Removal of Steel Protective/Guide Tube

7.6.1. Remove protective steel tube.

7.6.2. Remove the FRT.

7.6.3. Place Sealant Drying Cap over newly placed filter.

8. Conclusion

We were able to accomplish our goal of designing a set of tools that remove a single HEPA filter from an array of filters. This was a very open ended, design-based project, and we believe that we came up with a solution that is quick, easy, and inexpensive to continually use.

9. References

1. *HEPA Filter Repair Tool*. Erik Brown. Cal Poly, ATL Building, San Luis Obispo. 22 Sept. 2011. Presentation.
2. LLNL. *Statement of Work*. 16 Sept. 2011.
3. Meike, Annemarie. "Ceramic Filters." *Technology Transfer, Lawrence Livermore National Laboratory*. Web.
4. *3M Fire Barrier Water Tight Sealants*. 3M Center. Web. 17 Oct. 2011.
5. ISO 594:1986 "Conical fittings with a 6 % (Luer) taper for syringes, needles and certain other medical equipment".

10. Appendices

- A. Nondisclosure Agreement with the LLNL
- B. Calculations
- C. Tooling Bill of Materials
- D. Replacement Parts List
- E. Part Drawings

HEPA Filter Repair Tool

Appendix A: Nondisclosure Agreement with the LLNL

MUTUAL NONDISCLOSURE AGREEMENT FOR EXCHANGE OF INFORMATION WITH LAWRENCE LIVERMORE NATIONAL LABORATORY

This Agreement, effective on the date the last party signs, is made by and between CALIFORNIA POLYTECHNIC STATE UNIVERSITY (CAL POLY) located at One Grand Avenue, San Luis Obispo, CA 93407, and LAWRENCE LIVERMORE NATIONAL SECURITY, LLC, (LLNS), under its Contract No. DE-AC52-07NA27344 with the U.S. DEPARTMENT OF ENERGY ("DOE"), as operator of the LAWRENCE LIVERMORE NATIONAL LABORATORY ("LLNL"), located at 7000 East Avenue, Livermore, CA 94550.

WHEREAS LLNS, as operator of LLNL, and CALIFORNIA POLYTECHNIC STATE UNIVERSITY (hereinafter individually referred to as the "PARTY" or collectively as the "PARTIES") wish to exchange certain confidential and proprietary information relating to HEPA filter technology ("PROPRIETARY INFORMATION"), this Agreement will govern the conditions of mutual disclosure of PROPRIETARY INFORMATION by the PARTIES.

The PARTIES hereby agree:

- (1) To perform all terms of this Agreement and to maintain the PROPRIETARY INFORMATION in confidence, giving it the same degree of care, but no less than a reasonable degree of care, as the receiving PARTY exercises with its own proprietary information to prevent its unauthorized disclosure.
- (2) To exchange and use the PROPRIETARY INFORMATION solely for the purpose of evaluation, testing, and development of potential collaborations, joint ventures, and/or license of the technology
- (3) That neither PARTY, without the prior written consent of the other, will disclose any portion of the PROPRIETARY INFORMATION to others except to their employees, agents, consultants, subcontractors or Government personnel having a need to know in order to accomplish the sole purpose stated above, and who are bound by a like obligation of confidentiality under this Agreement. A list of all Cal Poly employees, professors, and students authorized to receive this information is attached hereto as Appendix A.
- (4) That neither PARTY will have any obligation, nor will the DOE, assume any liability with respect to any portion of the PROPRIETARY INFORMATION that:
 - (a) the receiving PARTY can demonstrate by written record was previously known to them;
 - (b) is, or becomes, available to the public through no fault of the receiving PARTY;
 - (c) is lawfully obtained by the receiving PARTY from a third party and is not subject to an obligation of confidentiality owed to the third party; or
 - (d) is independently developed by or for the receiving PARTY independent of any disclosure hereunder.
- (5) That PROPRIETARY INFORMATION disclosed by the PARTIES will be in writing and clearly marked "PROPRIETARY INFORMATION" or its equivalent. If such PROPRIETARY INFORMATION is initially disclosed orally or by demonstration, it will be identified as PROPRIETARY INFORMATION or its equivalent at the time of disclosure. The disclosing PARTY will, within thirty (30) days thereafter: (a) reduce such PROPRIETARY INFORMATION to writing or other tangible form, referencing the date and type of PROPRIETARY INFORMATION disclosed, and mark it as PROPRIETARY INFORMATION or its equivalent; and (b) deliver a copy to the receiving PARTY. All protections and restrictions as to use and disclosure will apply during such thirty (30) day period.
- (6) That all rights and title to the PROPRIETARY INFORMATION disclosed under this Agreement will remain the property of disclosing PARTY unless otherwise agreed to in writing by the PARTIES.
- (7) That PROPRIETARY INFORMATION provided by any disclosing PARTY to any receiving PARTY shall be returned to the disclosing PARTY within five (5) days of written request for such return by the disclosing PARTY.
- (8) That no copies shall be made by a receiving PARTY of any PROPRIETARY INFORMATION without the express written consent of the disclosing PARTY. Any copies so authorized shall be returned to the disclosing PARTY or destroyed in accordance with the term and demand provisions of this Agreement.
- (9) That the receiving PARTY agrees that with regard to any patent application provided as PROPRIETARY INFORMATION under this Agreement that no protest, public use proceeding, copied claims for provoking interference, or other action impeding issuance of any patent based on the disclosed application shall be filed by RECIPIENT prior to publication of such patent application.
- (10) The PARTIES agree that any photocopy or facsimile copy of this fully-executed Agreement shall have the same legal force and effect as any copy bearing original signatures of the PARTIES.

HEPA Filter Repair Tool

Technical Contact for Company:

Name: Mohammad Noori
Company: California Polytechnic State University
Address: One Grand Avenue
ME Department
San Luis Obispo, CA 93407
Phone: 805 756 5581
Email: mnocri@calpoly.edu

Technical Contact for LLNL:

Name: Erik Brown
Company: Lawrence Livermore National Laboratory
Address: 7000 East Avenue
L-546
Livermore, CA 94550
Phone: 925 422 0649
Email: Brown17@llnl.gov

It is further agreed that the furnishing of PROPRIETARY INFORMATION does not constitute any grant or license to the other PARTY for any legal rights now or hereinafter held by either PARTY.

This Agreement will be subject to, and interpreted in accordance with, the laws of the State of California.

Unless terminated earlier by thirty (30) days written notice by either PARTY to the other, this Agreement will remain in effect for two (2) years from the effective date, at which time the receiving PARTY will return or destroy the PROPRIETARY INFORMATION within thirty (30) days of the termination of this Agreement. If the PROPRIETARY INFORMATION is destroyed, a certificate of destruction must be furnished to the disclosing PARTY within the thirty (30) days. The secrecy and non-use obligations of the receiving PARTY set forth above will remain in effect for five (5) years from the effective date.

The receiving PARTY acknowledges its obligations to control access to technical data under the U.S. Export Laws and Regulations and agrees to adhere to such Laws and Regulations with regard to any technical data received under this Agreement.

Any modification to this Agreement must be in writing and signed by the duly authorized representative of each PARTY.

LAWRENCE LIVERMORE NATIONAL SECURITY, LLC,
LAWRENCE LIVERMORE NATIONAL LABORATORY

Signature: 

Name: Erik Stenehjorn
Title: Director, Industrial Partnerships Office

Date: 11/11/11

CALIFORNIA POLYTECHNIC STATE UNIVERSITY

Signature: 

Name: Dru Zachmeyer
Title: Associate Director of Contracts, Procurement and Risk Management

Date: 11/9/11

RETURN TO: Lawrence Livermore National Laboratory
ATTN: Terry Contreras L-795
7000 East Avenue
Livermore, CA 94550

cc: Annemarie Melke

Appendix B: Calculations

Shaft Analysis

Equations

Shaft Analysis

Material Properties

$$\rho_{Al} = 0.097 \text{ [lb/in}^3\text{]} \quad (1)$$

$$\rho_{Steel} = 0.282 \text{ [lb/in}^3\text{]} \quad (2)$$

$$E_{Steel} = 30 \cdot 10^6 \text{ [lb/in}^2\text{]} \quad (3)$$

$$V_{Pusher} = 6 \cdot 4 \cdot 2 \text{ [in}^3\text{]} \quad (4)$$

$$P_{Pusher} = \rho_{Al} \cdot V_{Pusher} \text{ [lb]} \quad (5)$$

$$L_{shaft} = 24 \text{ [in]} \quad (6)$$

$$D_{shaft} = .25 \text{ [in]} \quad (7)$$

$$V_{shaft} = \pi/4 \cdot (.5)^2 \cdot L_{shaft} \text{ [in}^3\text{]} \quad (8)$$

$$W_{shaft} = \rho_{Steel} \cdot V_{shaft} \text{ [lb]} \quad (9)$$

$$I_{shaft} = \frac{\pi \cdot ((D_{shaft})^4)}{64 \text{ [in}^4\text{]}} \quad \text{Assumes 1/4 in shaft} \quad (10)$$

Analysis

Max Deflection of Shaft

$$y_{max} = - (W_{shaft} + P_{pusher}) \cdot \frac{(L_{shaft})^3}{(192 \cdot E_{Steel} \cdot I_{shaft})} \text{ [in]} \quad (11)$$

Max Shear Stress in Shaft

$$\tau = \frac{4 \cdot (W_{shaft} + P_{pusher})}{(3 \cdot (\pi/4) \cdot (.25)^2)} \text{ [lb/in}^2\text{]} \quad (12)$$

Max Bending Stress in Shaft

$$\sigma = \frac{18 \cdot .125}{I_{shaft}} \text{ [lb/in}^2\text{]} \quad (13)$$

The max stresses are much less than the yield strength of steel

Solution

$$\begin{array}{ll} D_{shaft} = 0.25 & E_{Steel} = 3.000 \times 10^7 \\ I_{shaft} = 0.0001917 & L_{shaft} = 24 \\ P_{pusher} = 4.656 & \rho_{Al} = 0.097 \\ \rho_{Steel} = 0.282 & \sigma = 11734 \\ \tau = 162.6 & V_{pusher} = 48 \\ V_{shaft} = 4.712 & W_{shaft} = 1.329 \\ y_{max} = -0.07491 & \end{array}$$

Appendix C: Tooling Bill of Materials

Description	Quantity
Slider	1
Clip No Pusher	1
Clip With Pusher	1
Pusher Shaft	1
Pusher Plate	1
1/2" Internal Snap Ring	2
Linear Slider Bearings	2
Cap Screws	8
3/8" Internal Snap Ring	1
Protective Tube	1
Sealant Injector	1
Sealant Injector Shaft	1
Sealant Injector Handle	1
Drill Bit Extension	1
1/2 Wire Cup Brush	1
Automatic Center Punch	1
3/8" Shaft	2
Knurled Knob	1

Appendix D: Replacement Parts List

Replacement Parts List		
Description	Supplier	Part Number
Linear Ball Bearing 3/8" Shaft Diameter	McMaster-Carr	6489K62
Aluminum Knurled Knob 1/4"-20 Threaded	McMaster-Carr	6077K22
Automatic Center Punch	McMaster-Carr	34225A65
Drill Bit Extension	McMaster-Carr	3127A78
Black-Oxide Steel Cap Screws	McMaster-Carr	91251A245
Hardened Precision 440c Stainless Steel Shaft	McMaster-Carr	6253K35
Black Finish Steel Internal Retaining Ring	McMaster-Carr	99142A370
Right-Hand Threaded Connecting Rod, 12" Overall Length, 10-32 Threaded Male Ends	McMaster-Carr	6516K12
1/2" Wire Cup Brush	ToolTopia.com	FIR1423-2106

Note: These are all parts we purchased off-the-shelf and did not custom make. If these ever need to be replaced, one should refer to this table.

Appendix E: Part Drawings

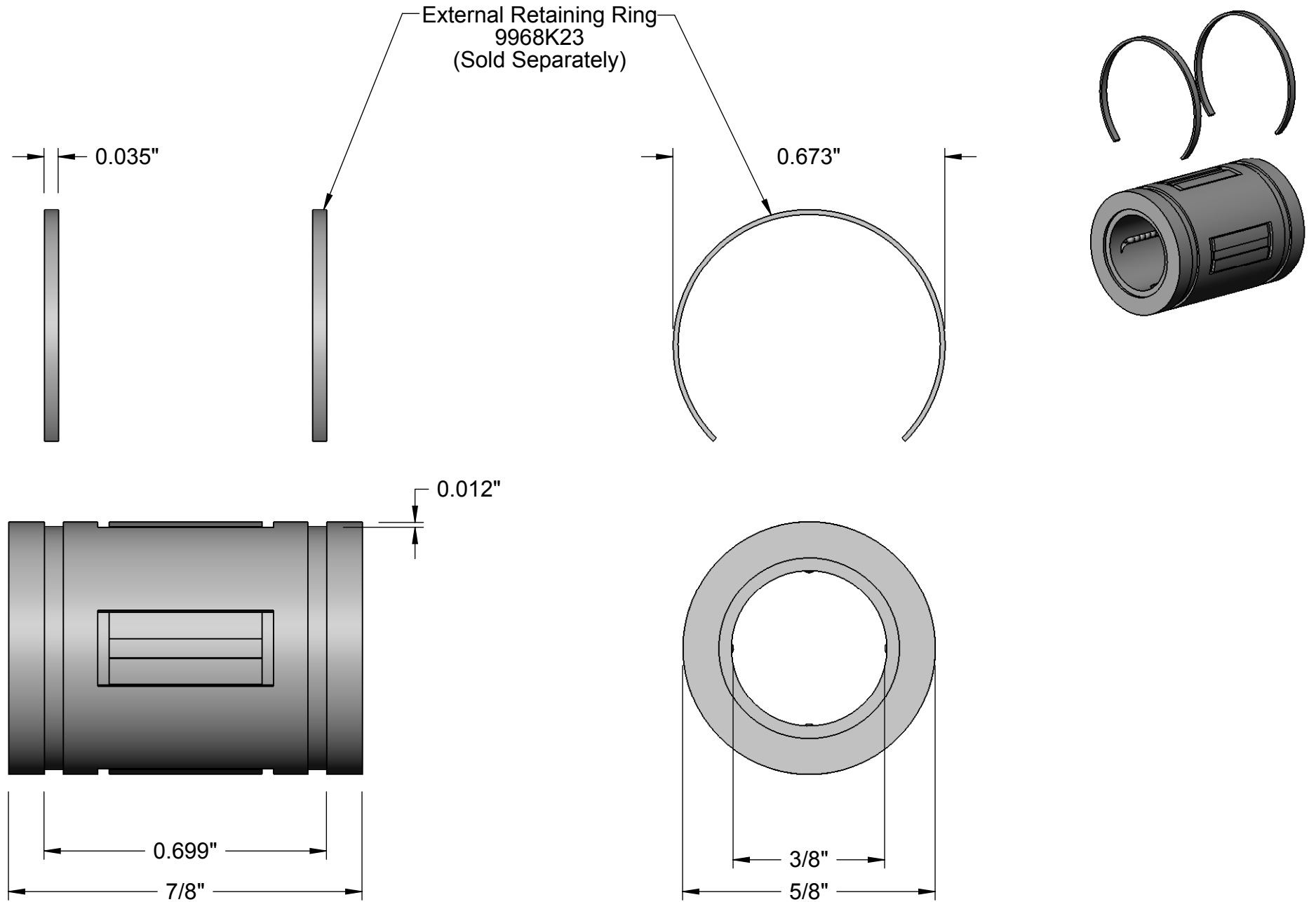

McMASTER-CARR CAD

PART
NUMBER

6489K62

<http://www.mcmaster.com>
© 2011 McMaster-Carr Supply Company

Information in this drawing is provided for reference only.

Self-Aligning
Linear Ball Bearing

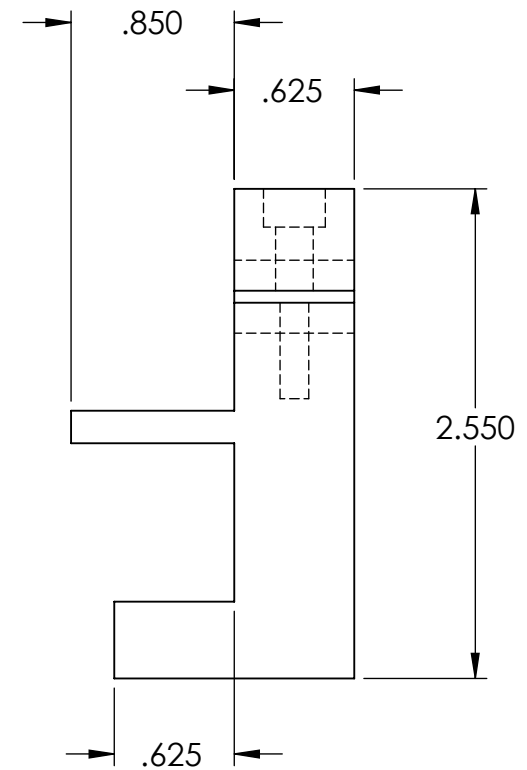
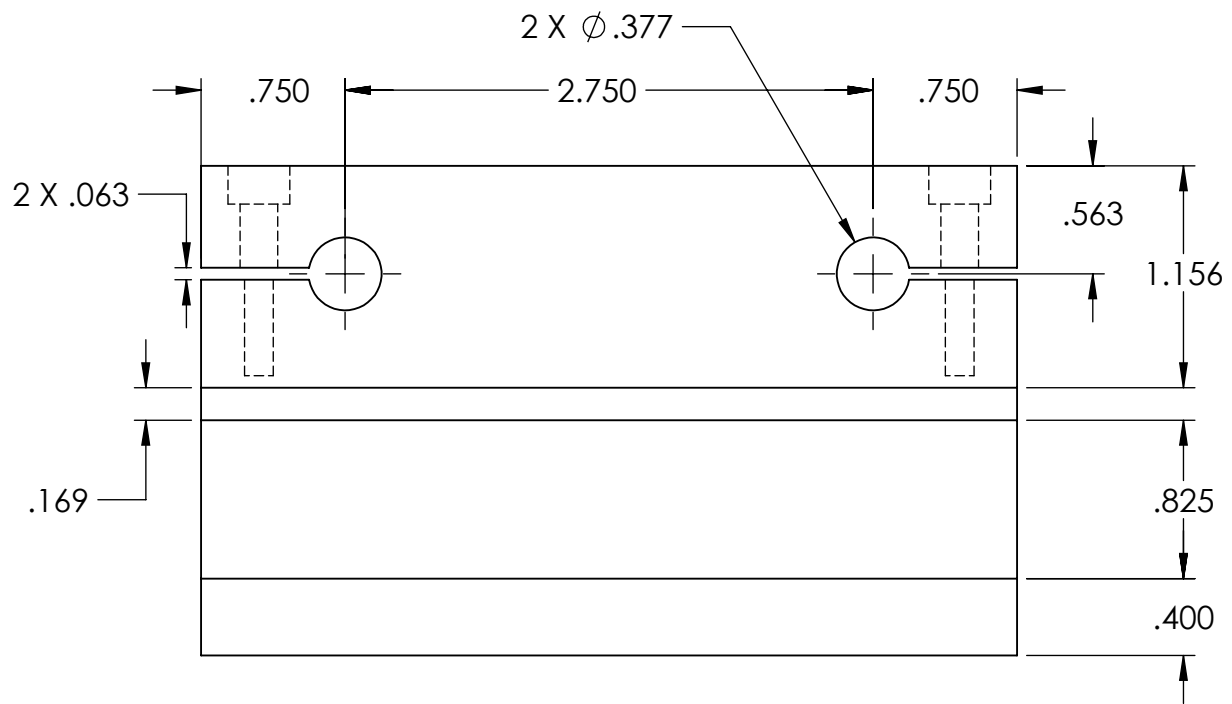
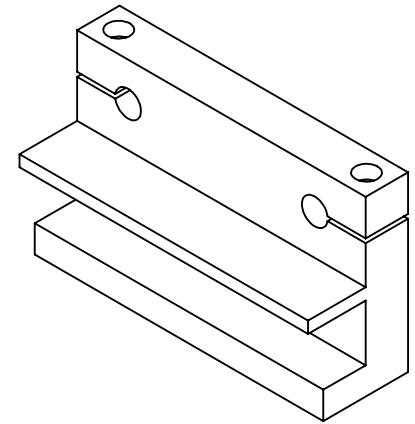
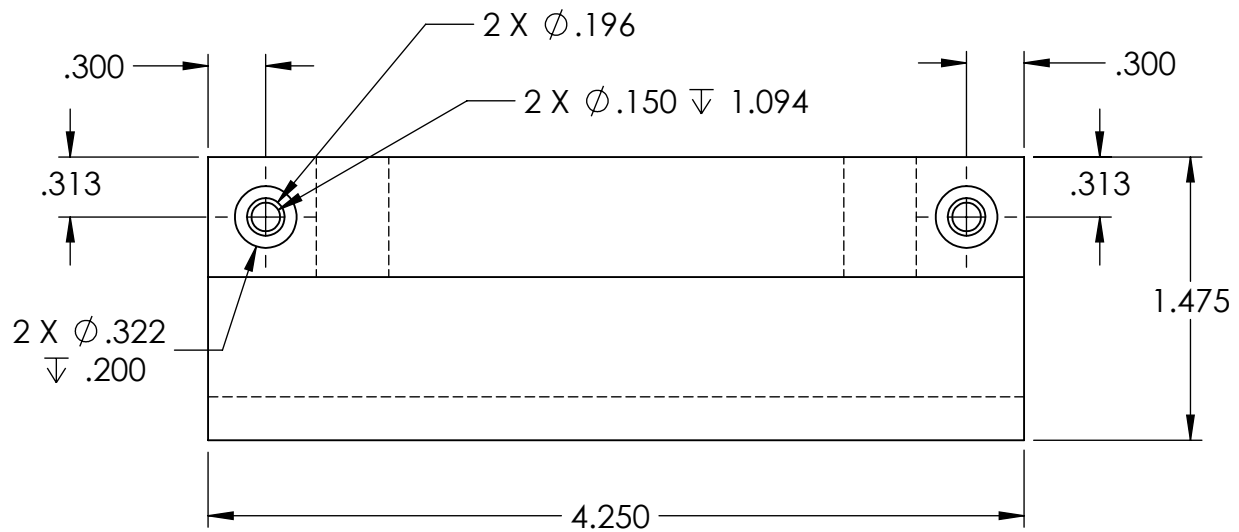

Cal Poly Mechanical Engineering
HEPA REPAIR TOOL

Title: Clip_NoPusher
Dwg. #:

Date:

Drwn. By:
Chkd. By:

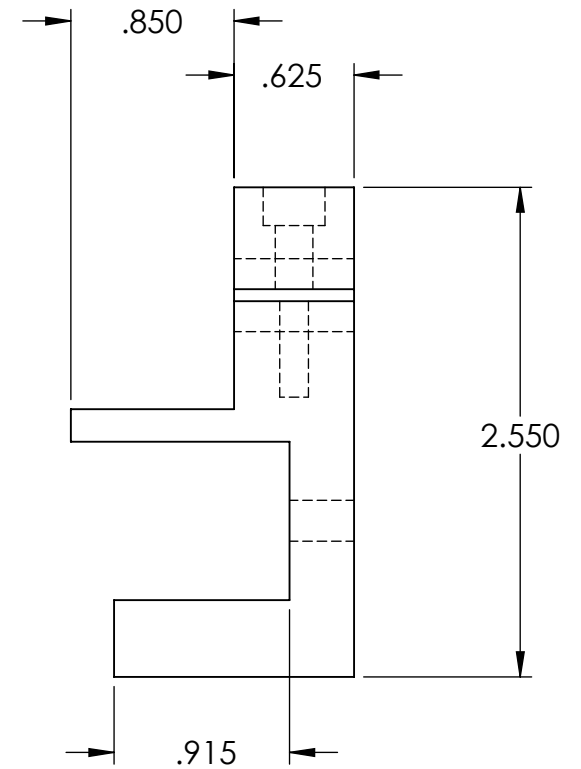
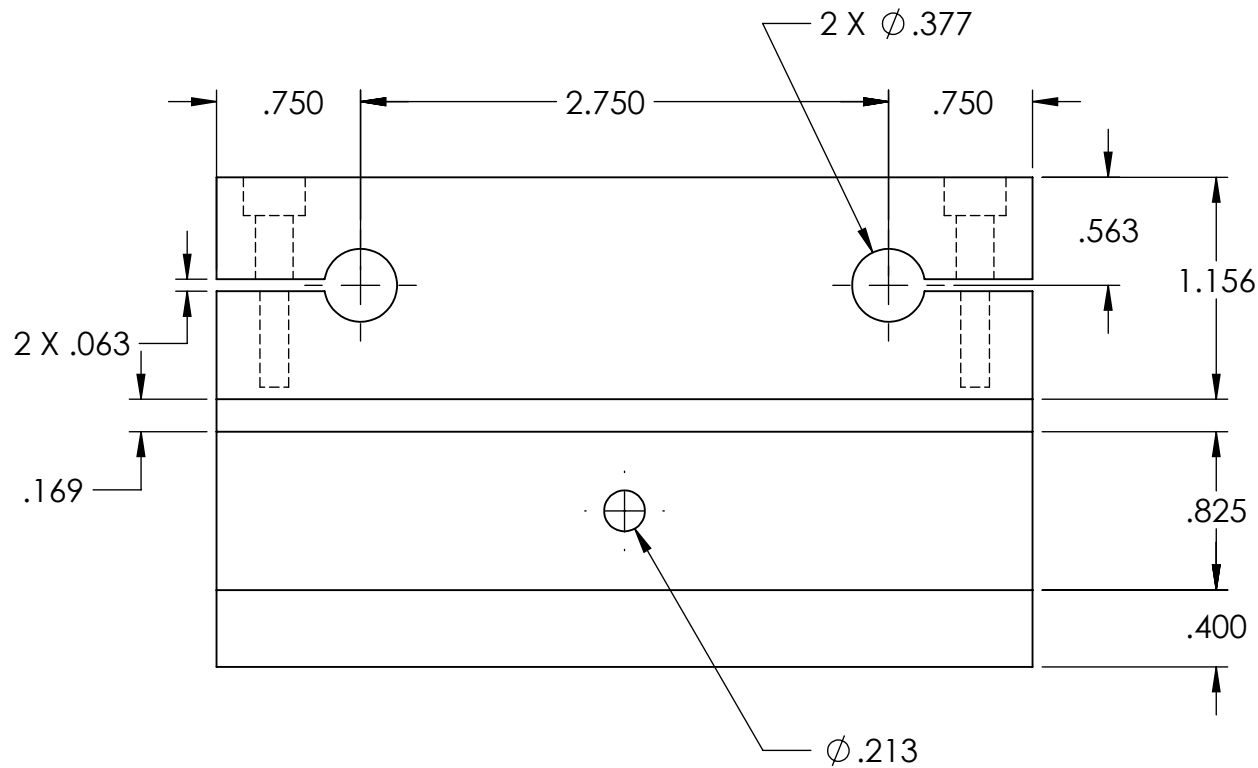
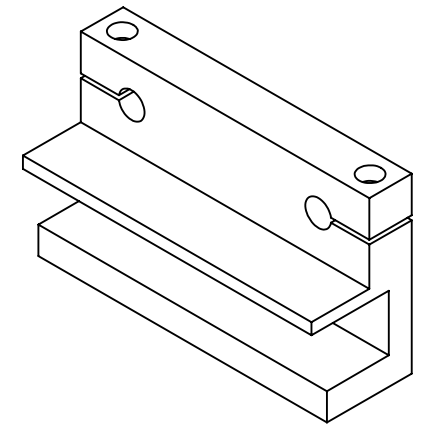
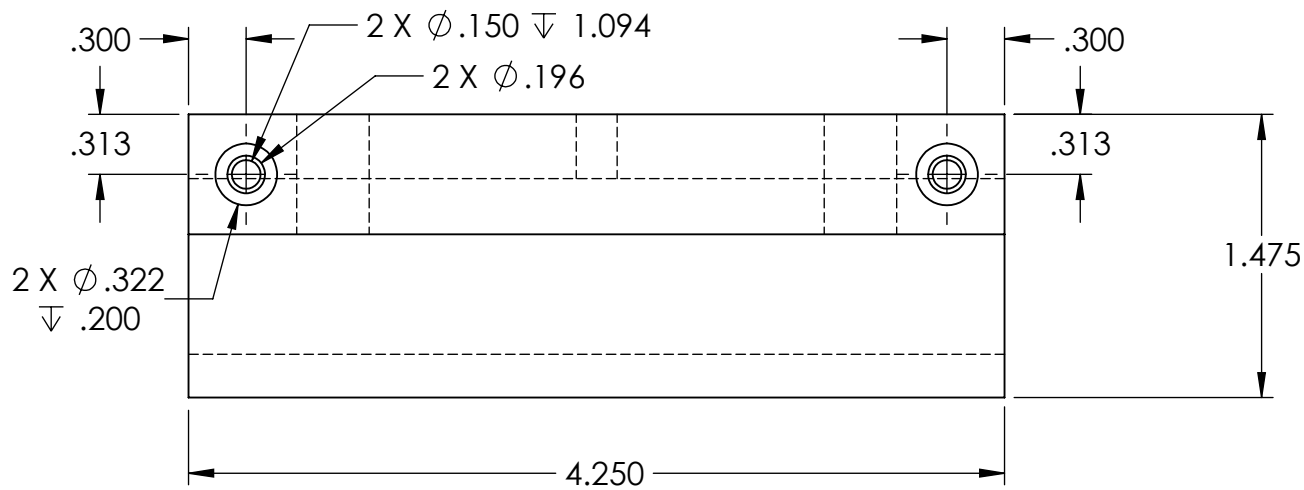

Cal Poly Mechanical Engineering
HEPA REPAIR TOOL

Title: Clip_WithPusher

Dwg. #:

Date:

Scale:

Drwn. By:

Chkd. By:

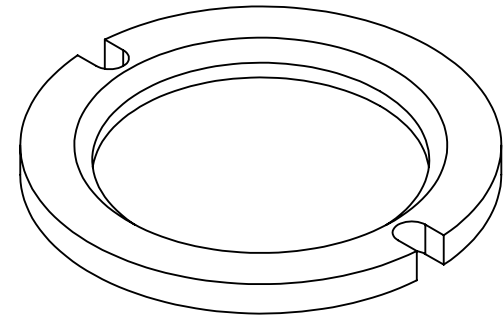
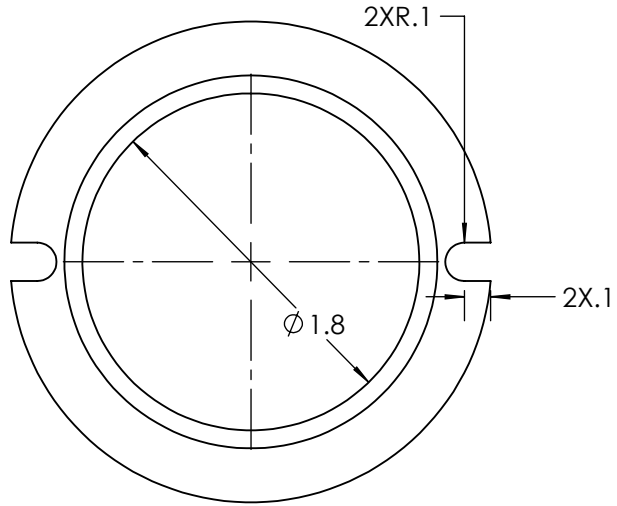

FLANGE

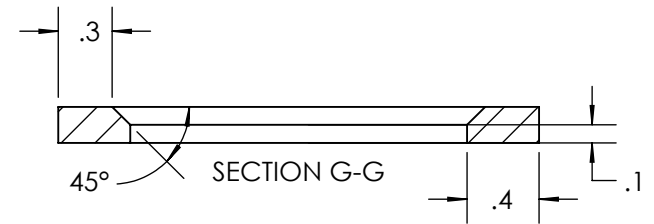
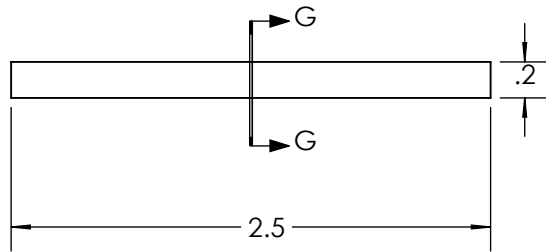

DRAWN BY: ADAM TACKITT

INIT:

CKD BY: P.B.

INIT:

TOLERANCE:

UNITS: INCH

MATERIAL: 4130 STEEL

NEXT ASSY:

SCALE: 1:1

TITLE: FLANGE

DWG #:

DATE: 3/29/12

GROUP:

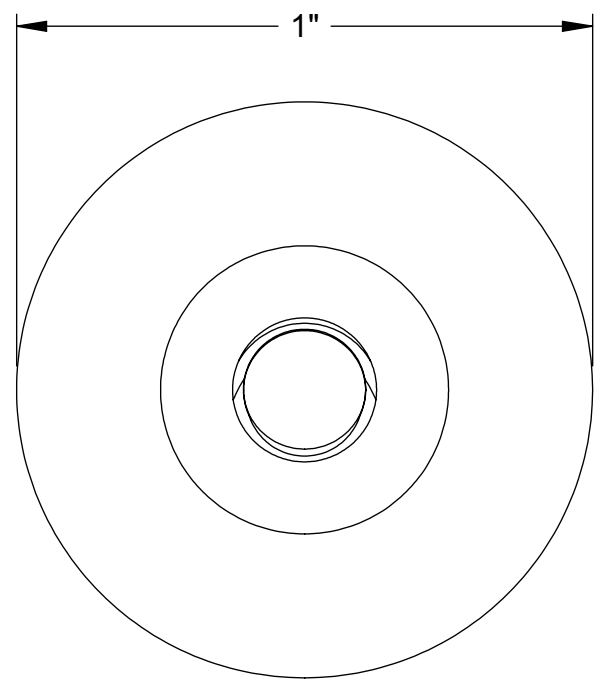
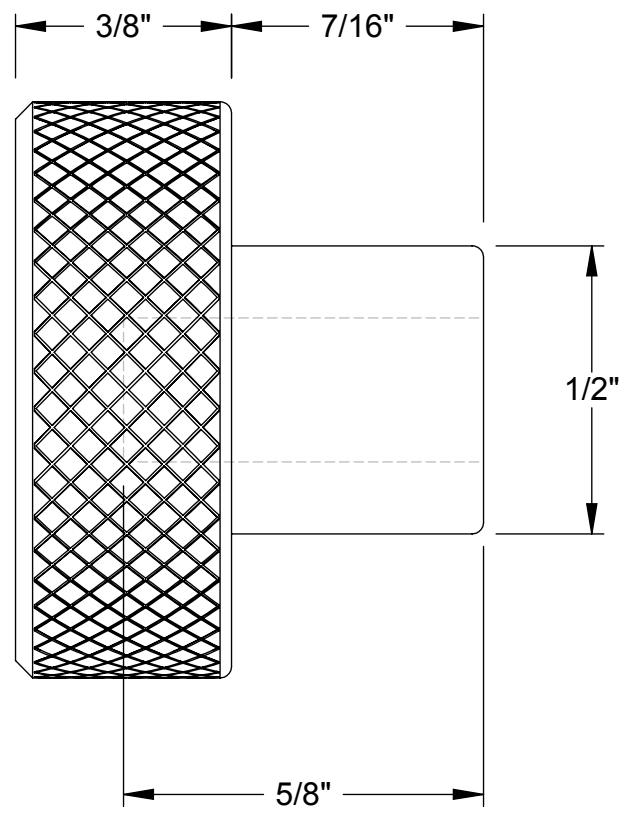
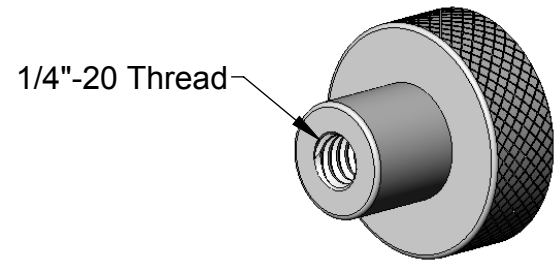

McMASTER-CARR <small>CAD</small>	PART NUMBER	6077K22
http://www.mcmaster.com		Aluminum Round Threaded Knob
© 2010 McMaster-Carr Supply Company		
Information in this drawing is provided for reference only.		

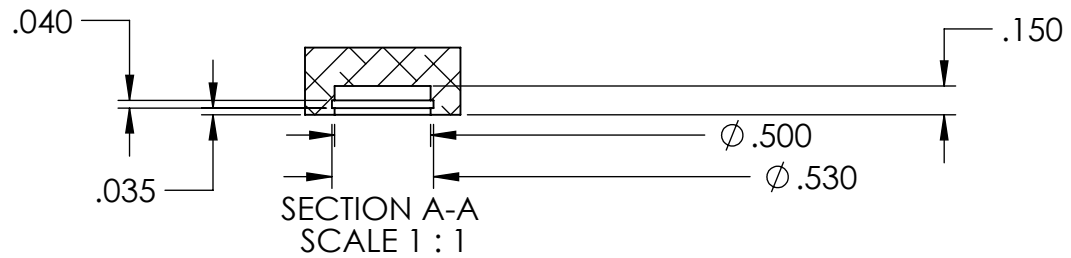
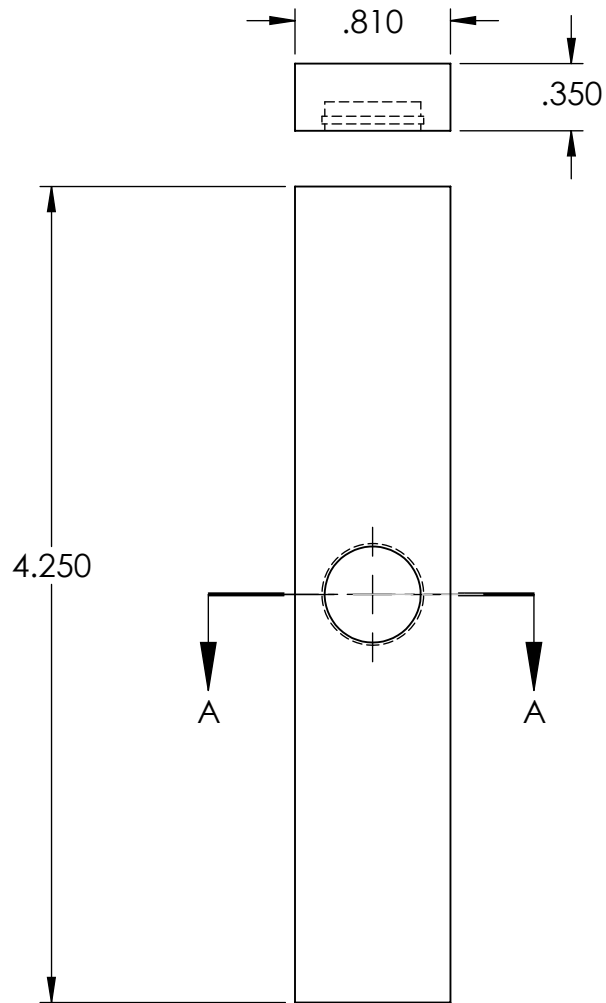

Cal Poly Mechanical Engineering
HEPA REPAIR TOOL

Title: PusherPlate

Dwg. #:

Date:

Scale: 1 : 1

Drwn. By: P. B.

Chkd. By: A. T.

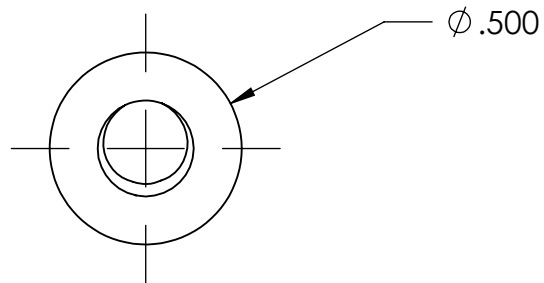
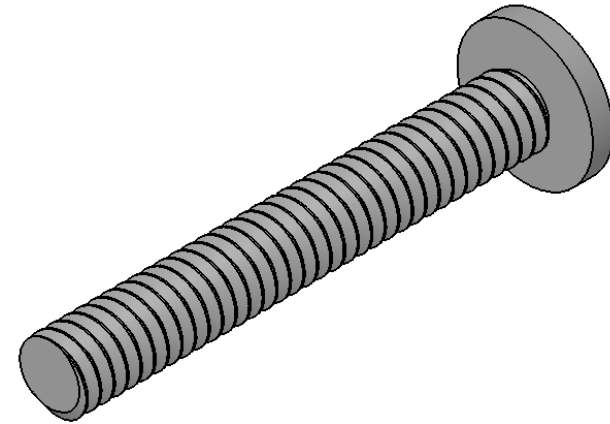
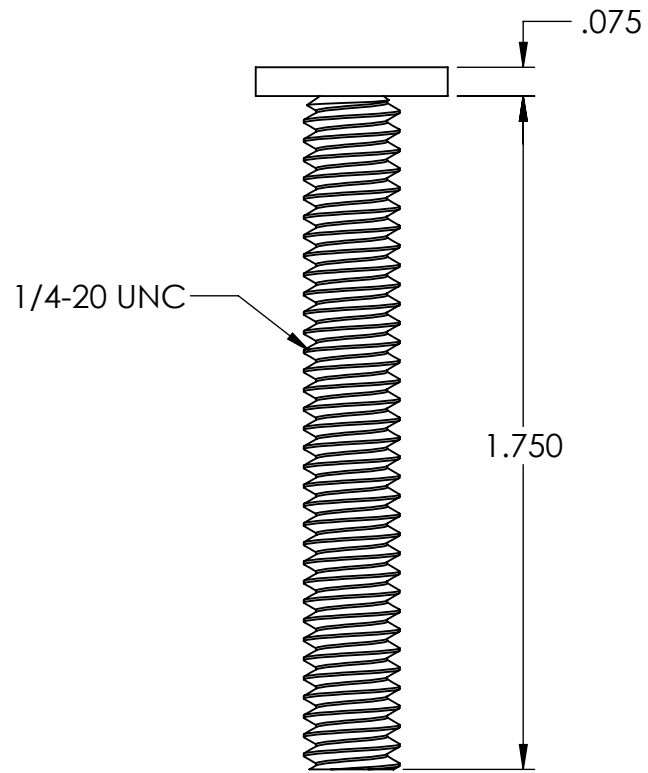

Cal Poly Mechanical Engineering
HEPA REPAIR TOOL

Title: Pusher Shaft

Dwg. #:

Date:

Scale: 2:1

Drwn. By: P.B.

Chkd. By: A.T.

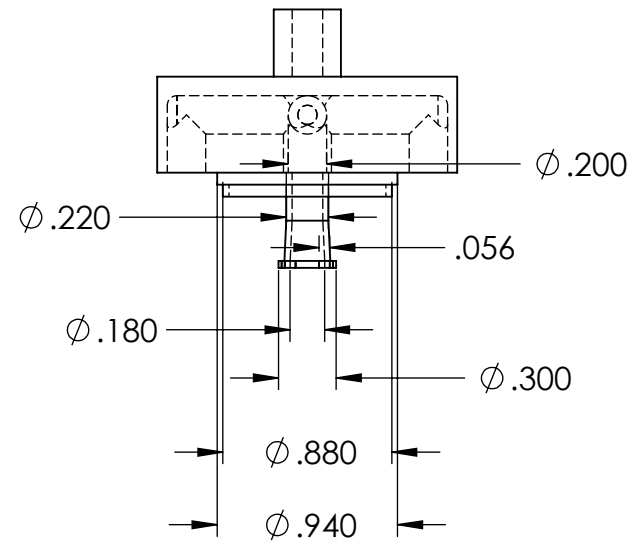
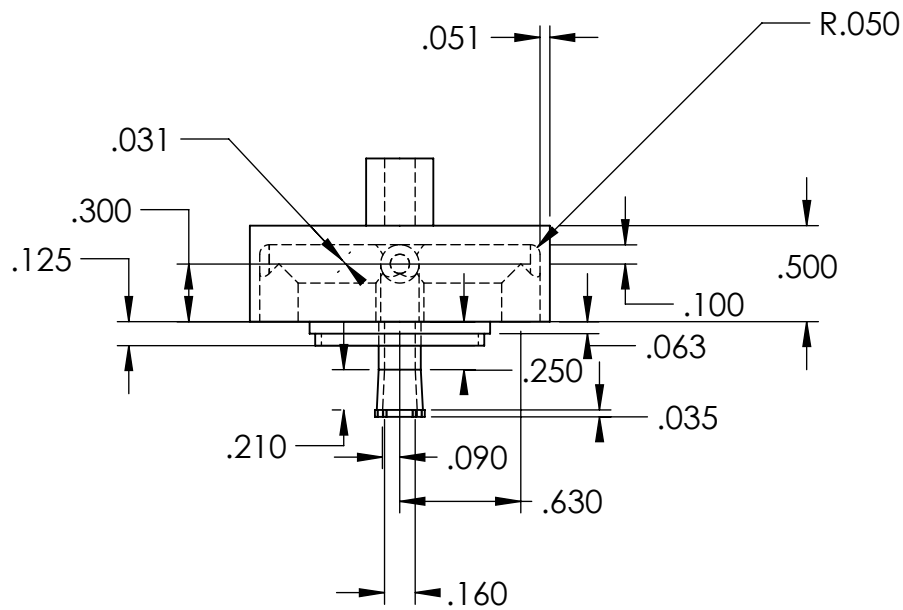
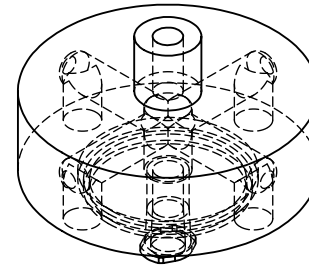
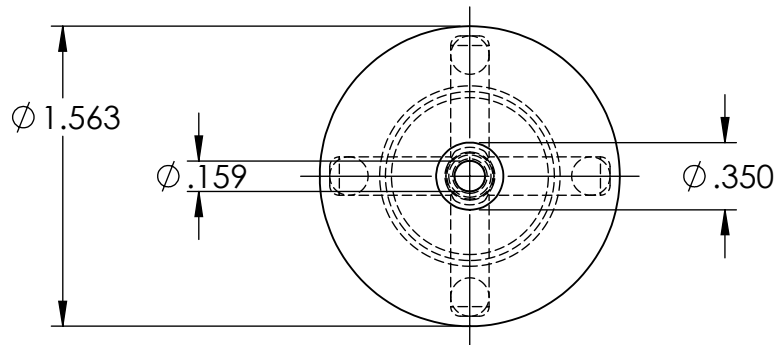

Cal Poly Mechanical Engineering
HEPA REPAIR TOOL

T

Dwg. #:

Nxt Asb:

Title: Sealant Injector

Date:

Scale: 1:1

Drwn. By: A.T.

Chkd. By: P.B.

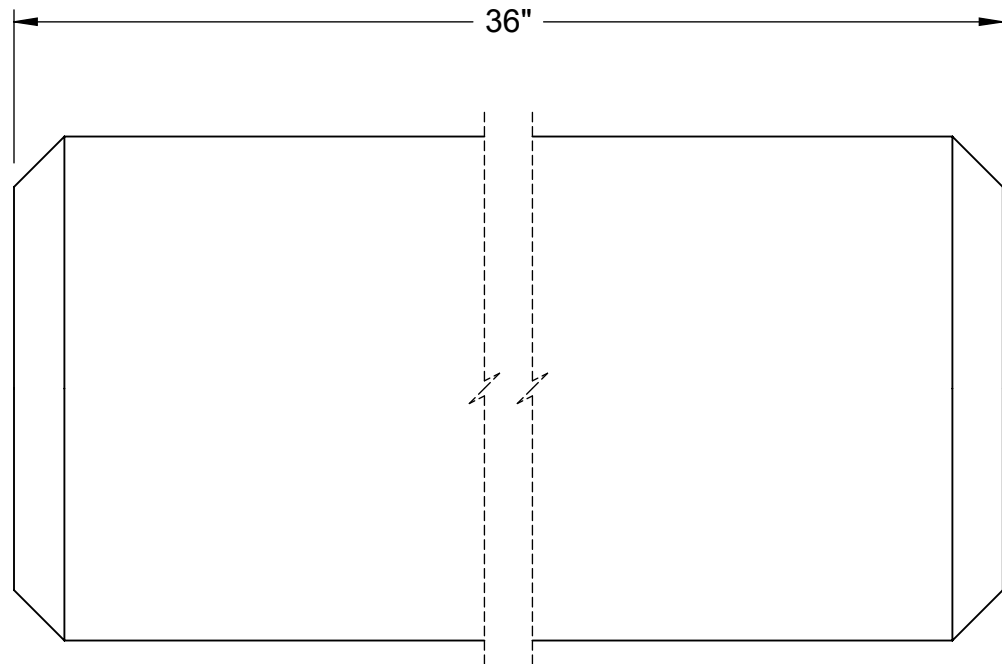
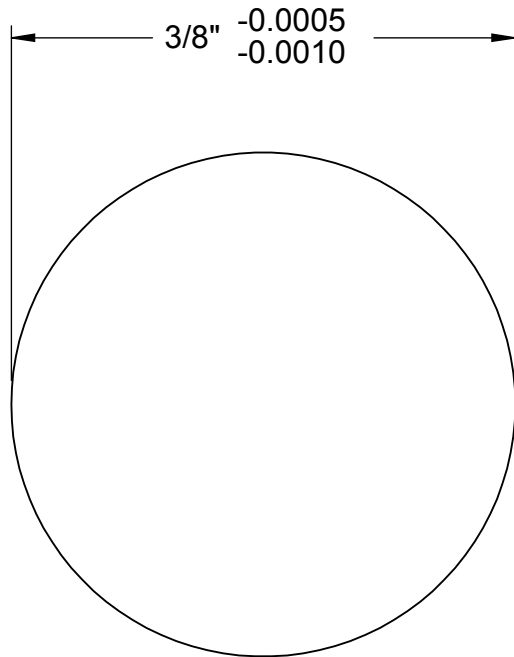
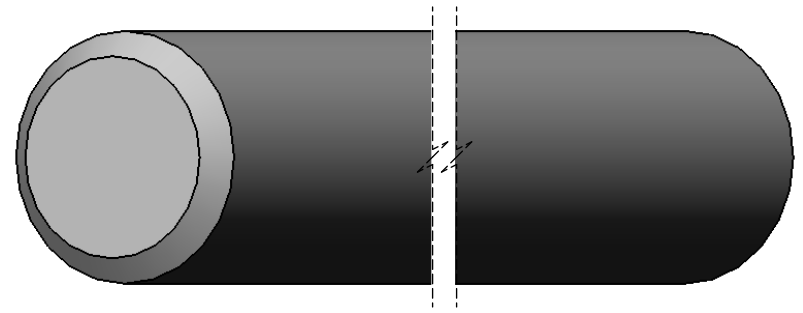

Straightness Tolerance is 0.002" per Foot.

McMASTER-CARR <small>CAD</small>	PART NUMBER	6253K35
http://www.mcmaster.com		440C Series Stainless Steel
© 2012 McMaster-Carr Supply Company		Hardened Shaft
Information in this drawing is provided for reference only.		

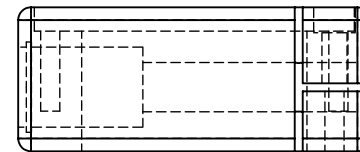
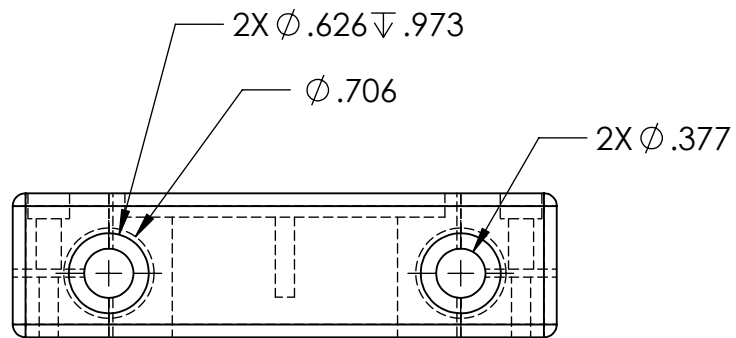
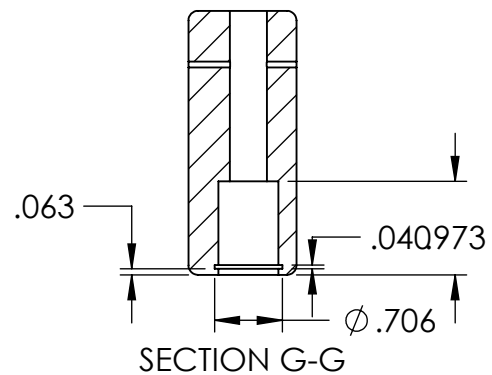
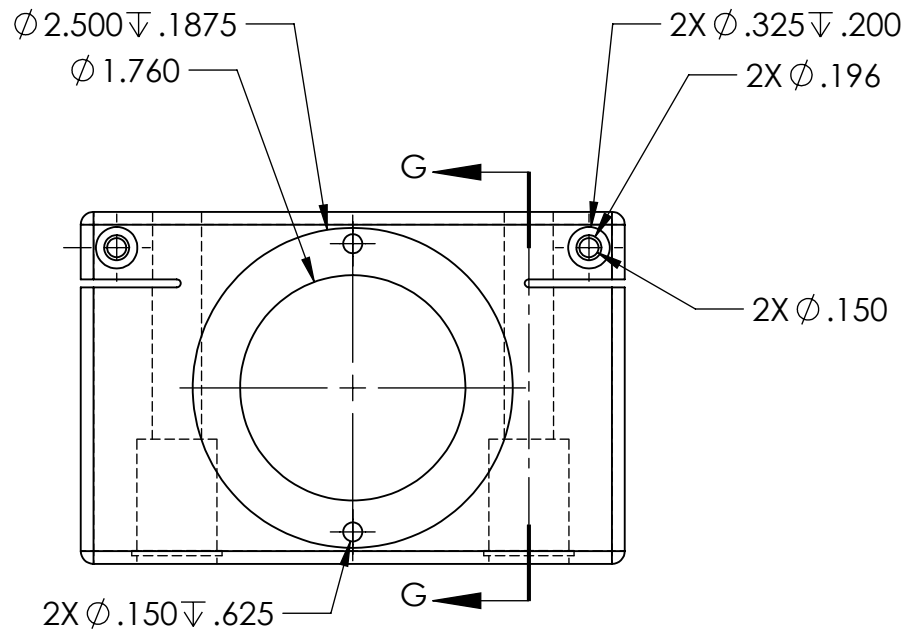

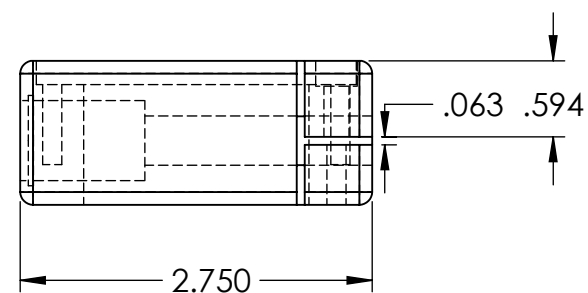
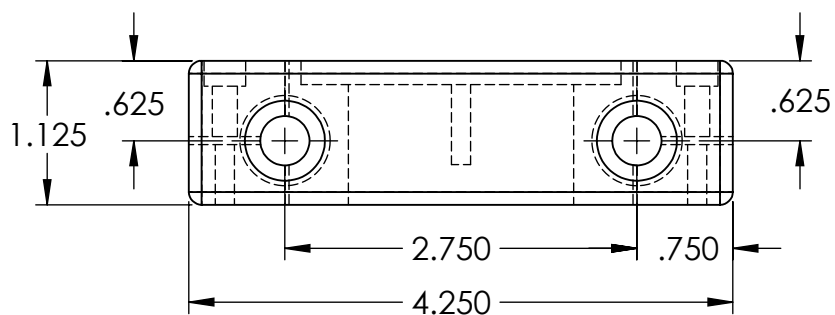
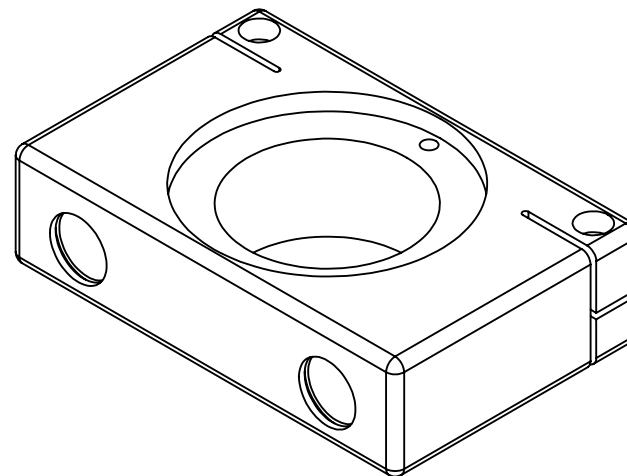
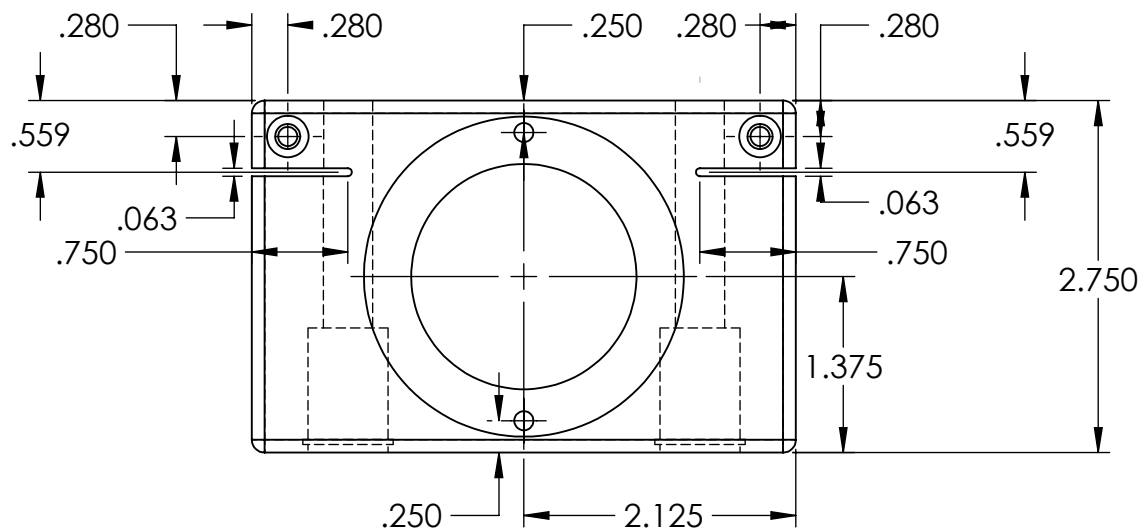

Cal Poly Mechanical Engineering
HEPA REPAIR TOOL

Title: LINEAR SLIDER

Dwg. #:

Date: 3/6/12

Scale: 2:3

Drwn. By: ADAM TACKITT

Chkd. By: PHIL BLACKLOCK

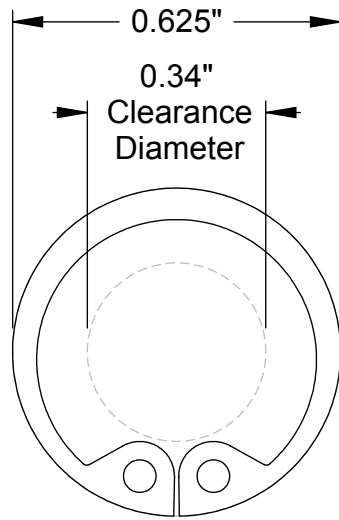

Compressed in Bore

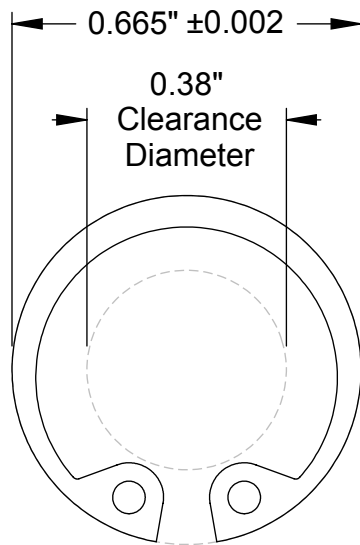

Released in Groove

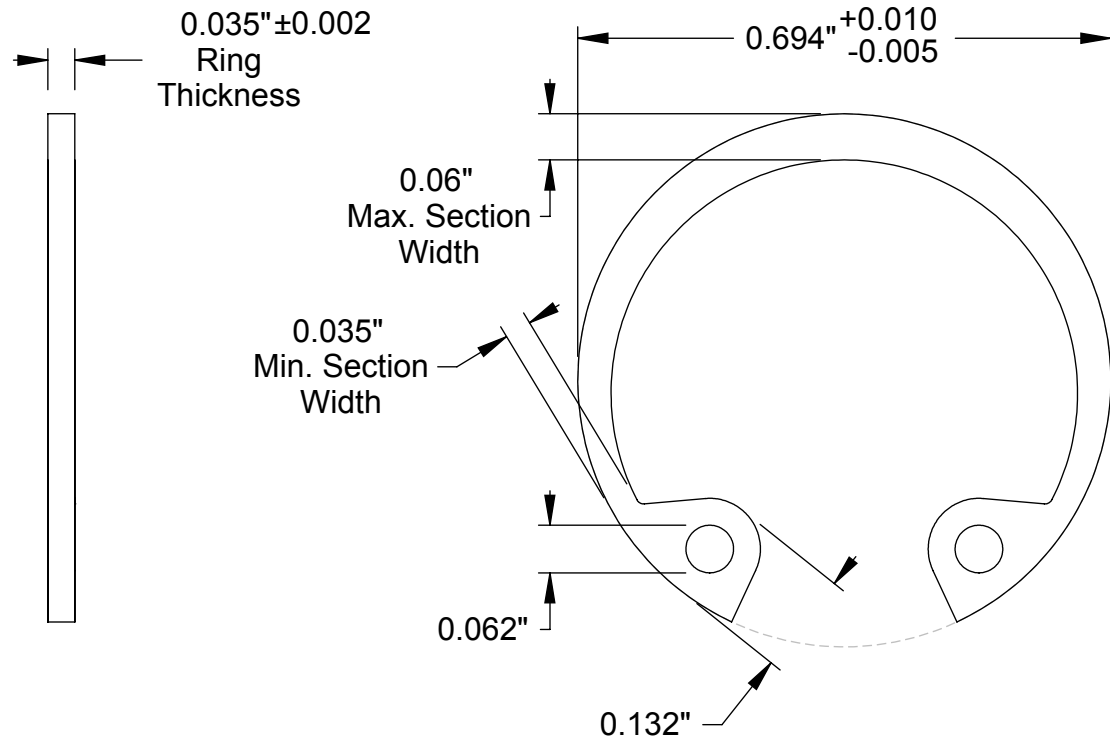
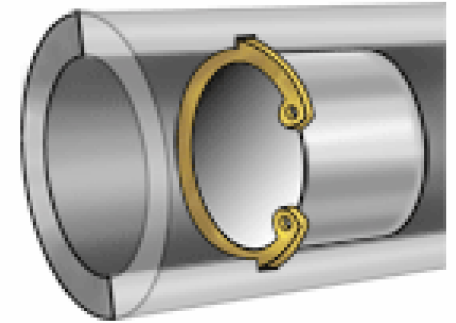
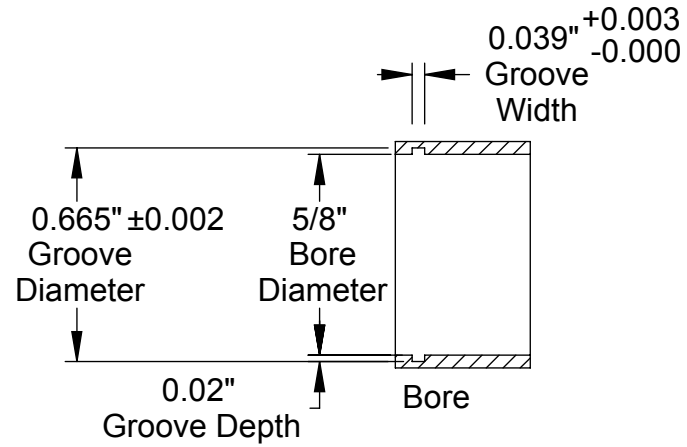

Note: Clearance diameter is the diameter of a shaft that can pass freely through the ring.

McMASTER-CARR CAD

PART NUMBER

99142A370

<http://www.mcmaster.com>
© 2011 McMaster-Carr Supply Company

Black-Finish Steel
Internal Retaining Ring

Information in this drawing is provided for reference only.

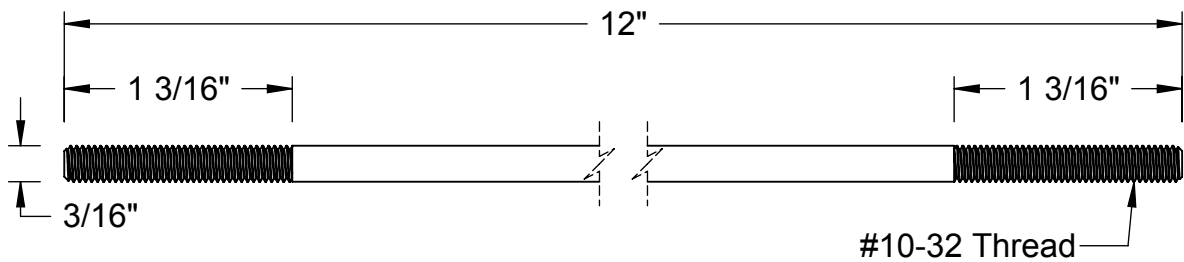
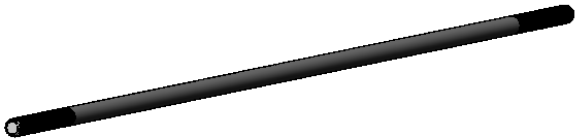

McMASTER-CARR CAD

PART
NUMBER

6516K12

<http://www.mcmaster.com>
© 2012 McMaster-Carr Supply Company

Zinc-Plated Steel Right-Hand
Male-Threaded Connecting Rod

Information in this drawing is provided for reference only.