

e=MSC^x

ENGINEERING. EDUCATION. ENTERPRISE.
2009 VPD
VIRTUAL
PRODUCT
DEVELOPMENT
CONFERENCE

Integrating ADAMS Software into an Upper Division Mechanical Design and Analysis Course

Xi Wu, Assistant Professor, **California Polytechnic State University**

Dewen Kong, Professor, Jilin University

Jim Meagher, Professor, California Polytechnic State University





Outline

- Introduction to rotating machinery design and analysis course: ME518.
- Gear profile design using MATLAB and CAD program.
- Crank-slider mechanism and two-stage gear box.
- Three types of planetary gear transmission systems.
- Comparison of the ADAMS simulation results with theoretical results.
- Vibration signals synchronous with gear mesh frequency and input speed.
- Changes in vibration signatures due to damage in transmission components.

Gear Tooth Profile Design

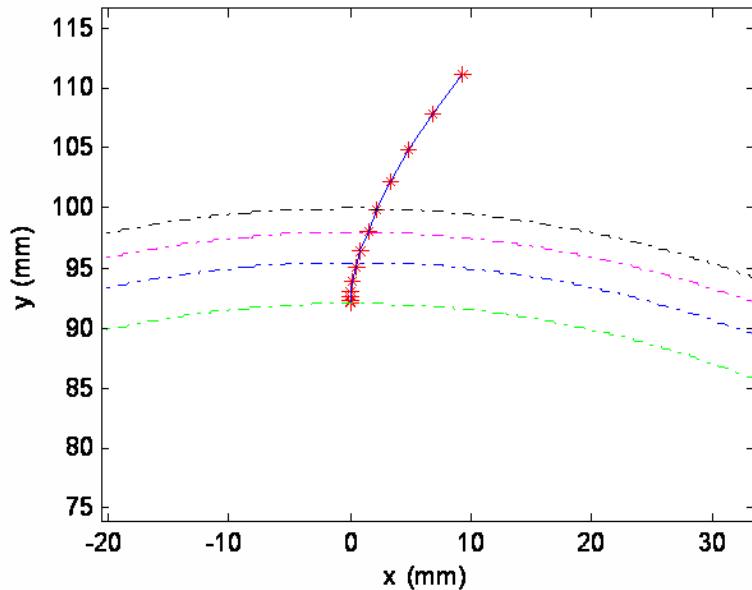

MATLAB plot for gear tooth profile

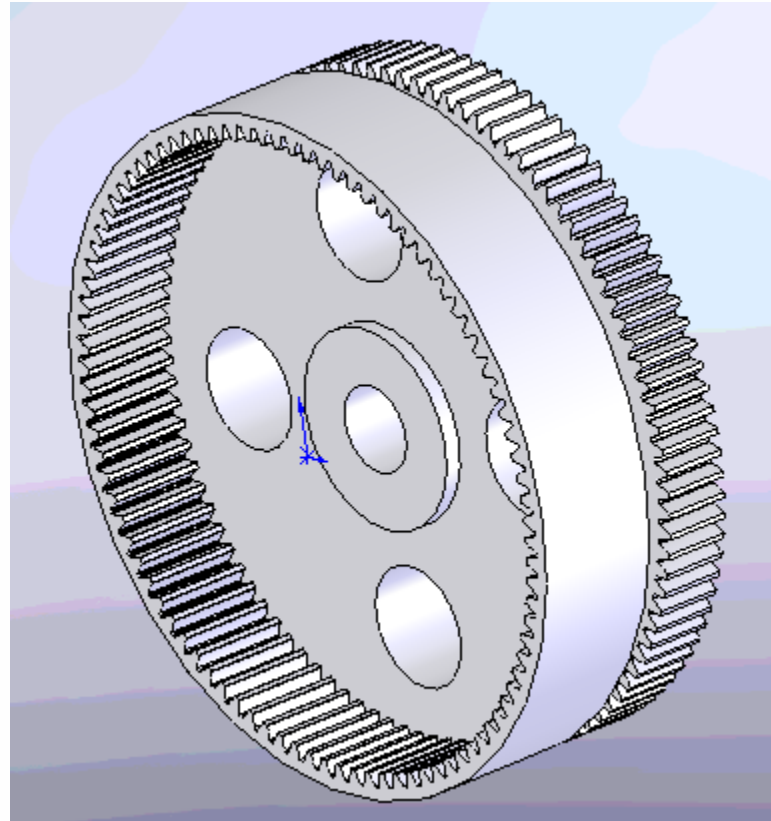

Note: In order to generate external tooth and internal tooth, respectively, the profile should be rotated different angles in different directions.

Crank Slider Mechanism Assembly I

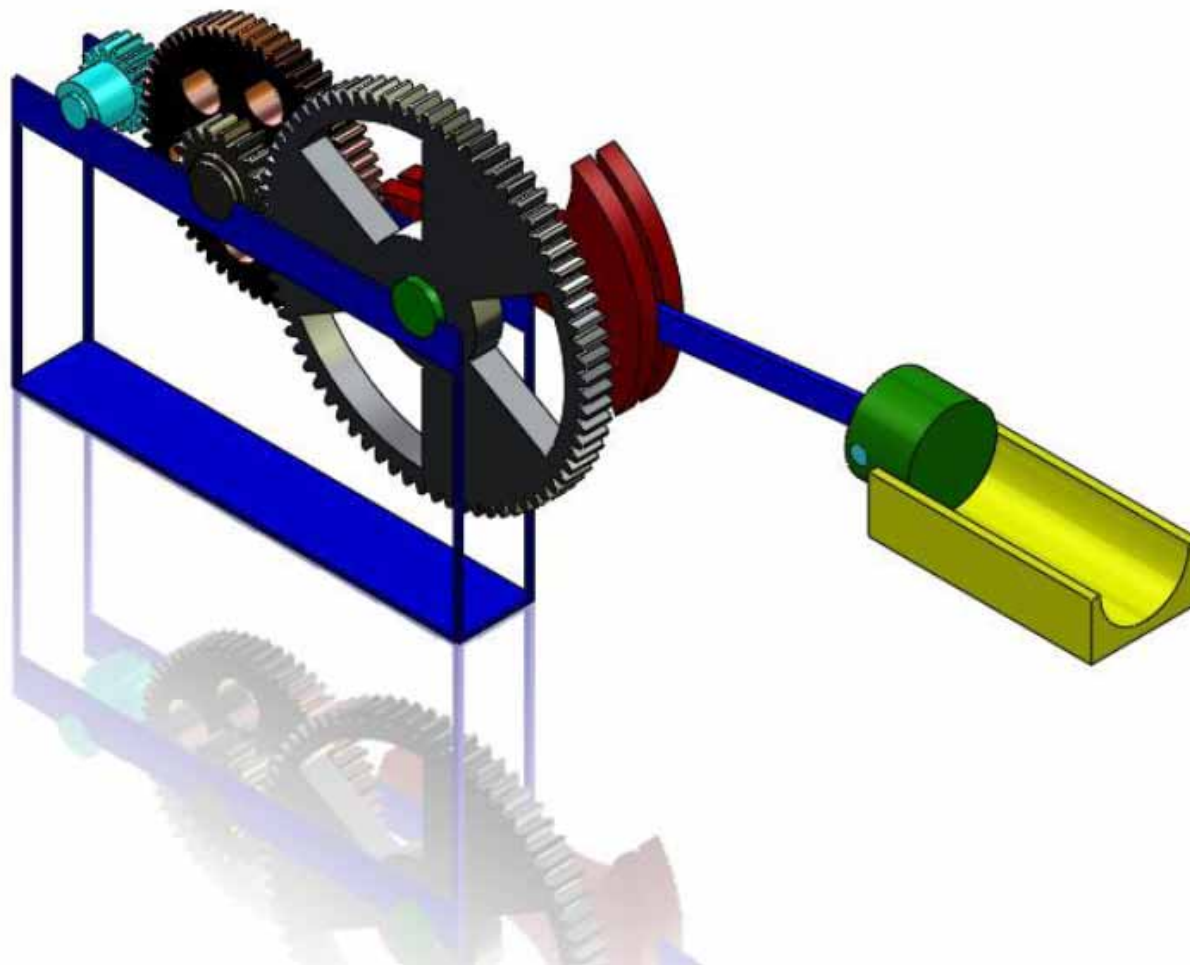

Design goal:

input power: $P_1=22\text{kW}$;

input angular velocity:

$n_1=1500\text{ rpm}$;

gear ratio: $i=13.375$;

Crank Slider Mechanism Assembly II

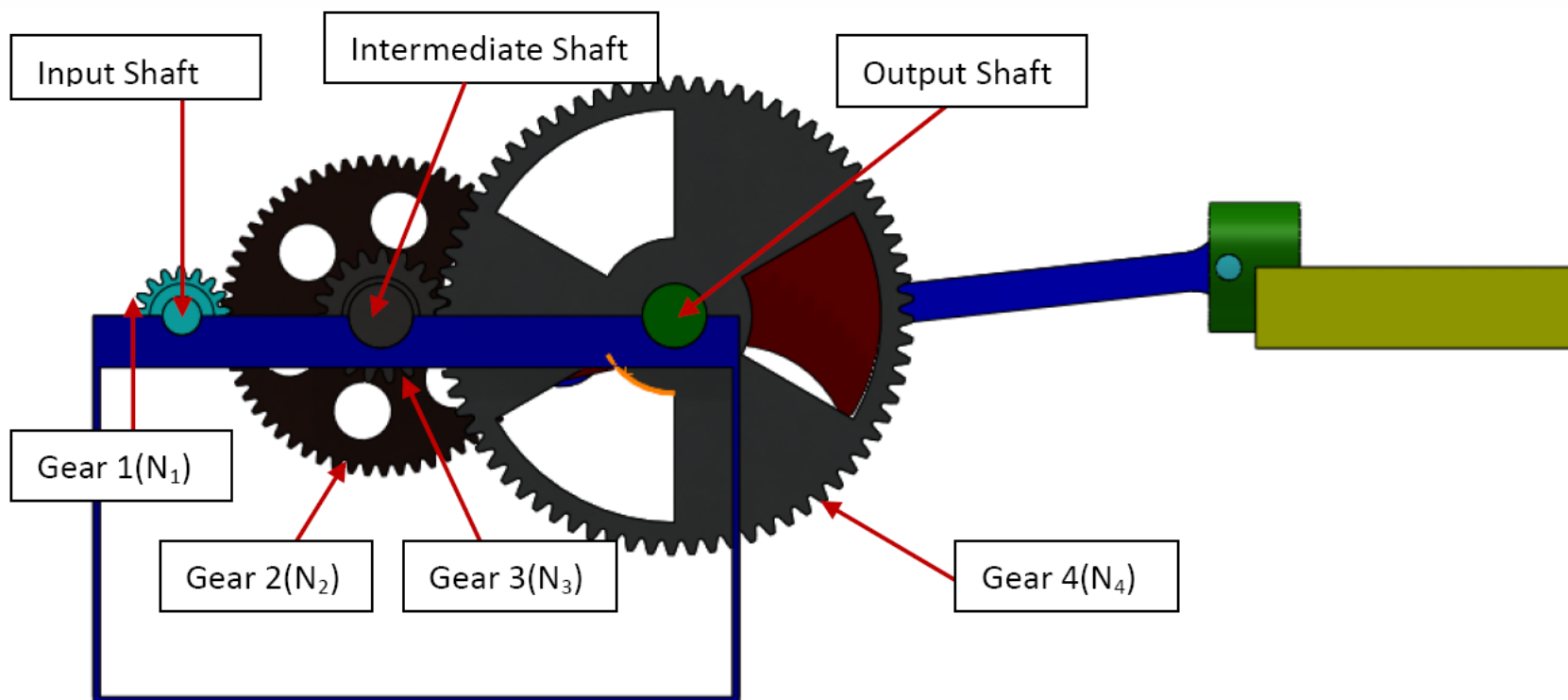

Number of teeth: $N_1=17$, $N_2=60$, $N_3=19$, $N_4=72$

Gear Modules: $m_1 = 4$, $m_2 = 5$

Crank Slider Mechanism Components

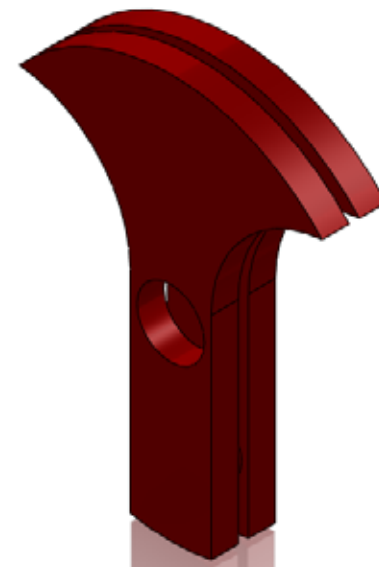
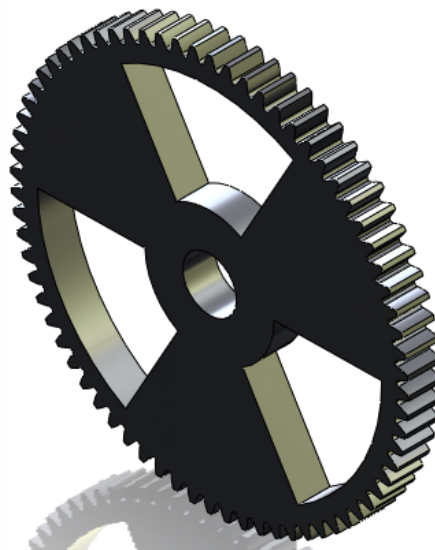
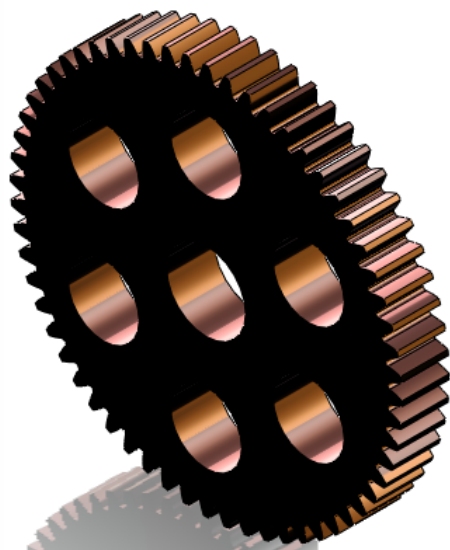
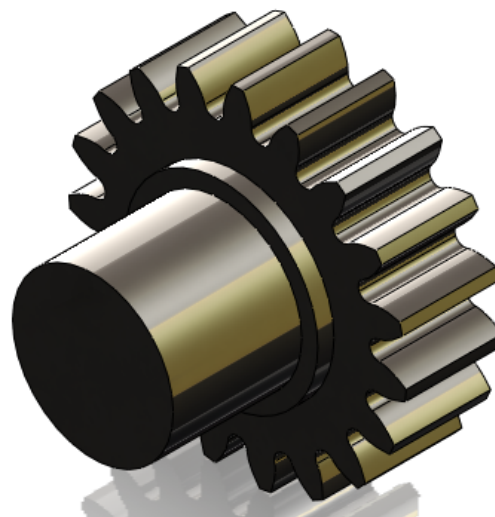
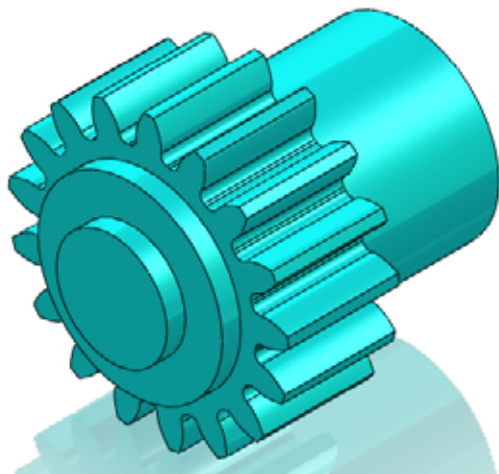

ADAMS Simulation Result I

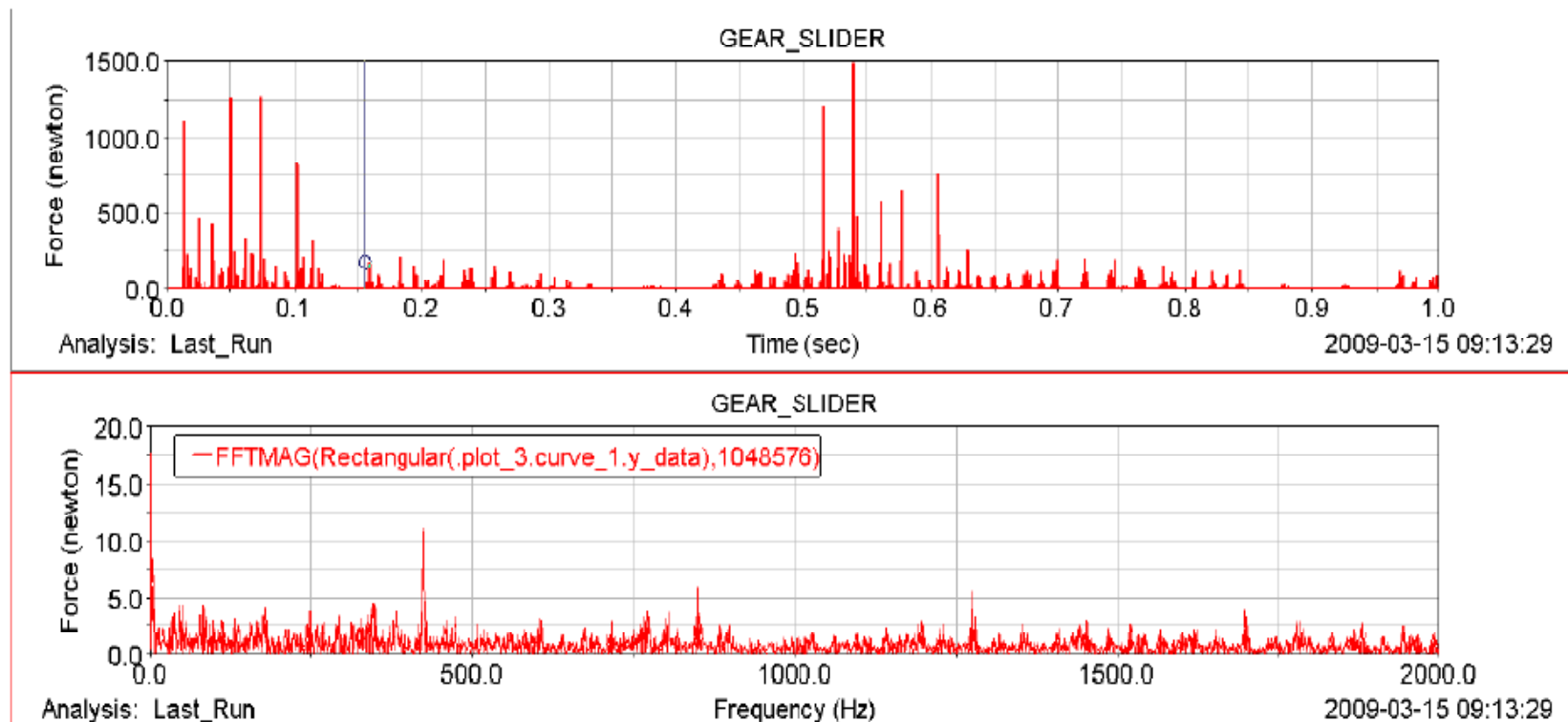

Time base and FFT plots of the contact forces in gear pair 1-2 for a healthy crank-slider mechanism

ADAMS Simulation Result II

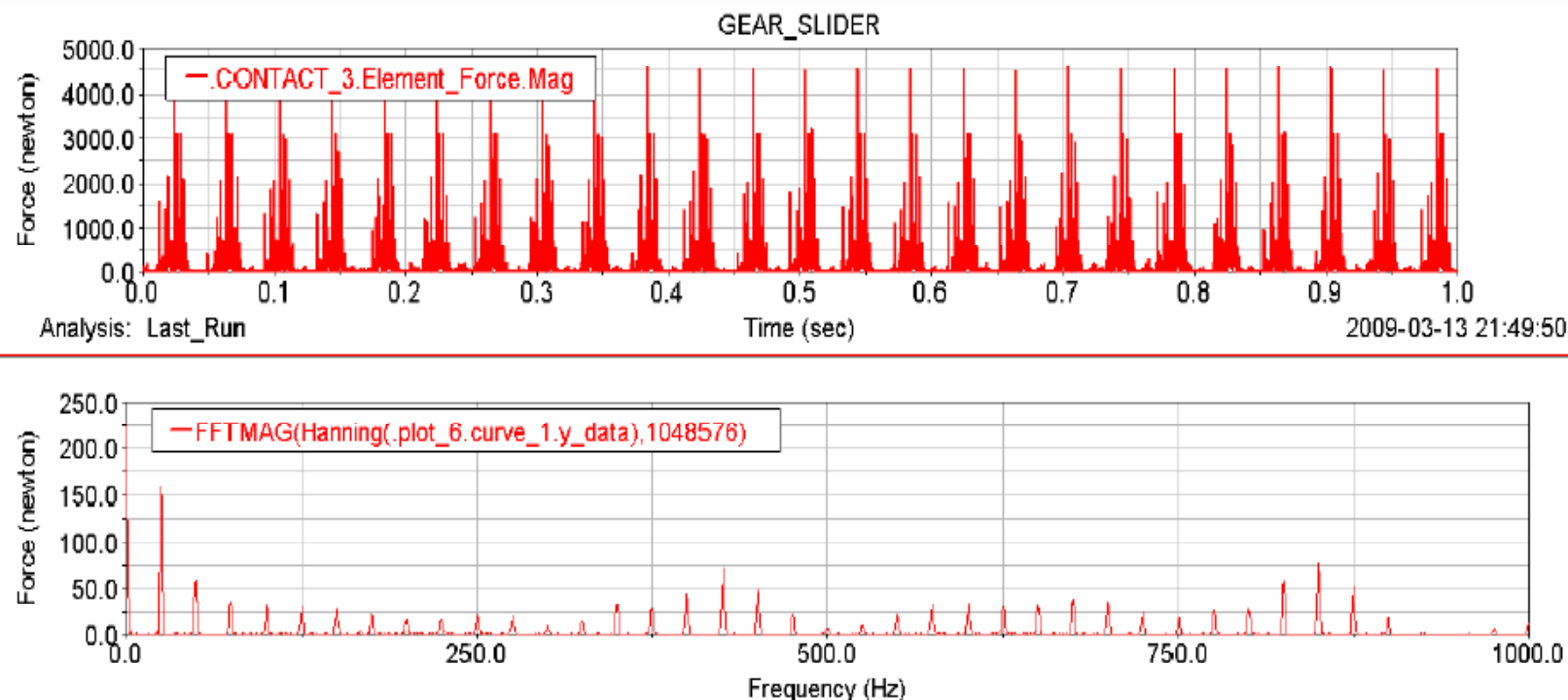

Time base and FFT plots of the contact forces in gear pair 1-2 for a crank-slider mechanism with a damaged pinion tooth.

Practical Gear Box Design



This is a practical gear train in vibration Lab.

Design parameters:

Face width: $\frac{3}{4}$ in;

Diametral Pitch: 12 teeth/inch;

Pressure Angle: 14.5°

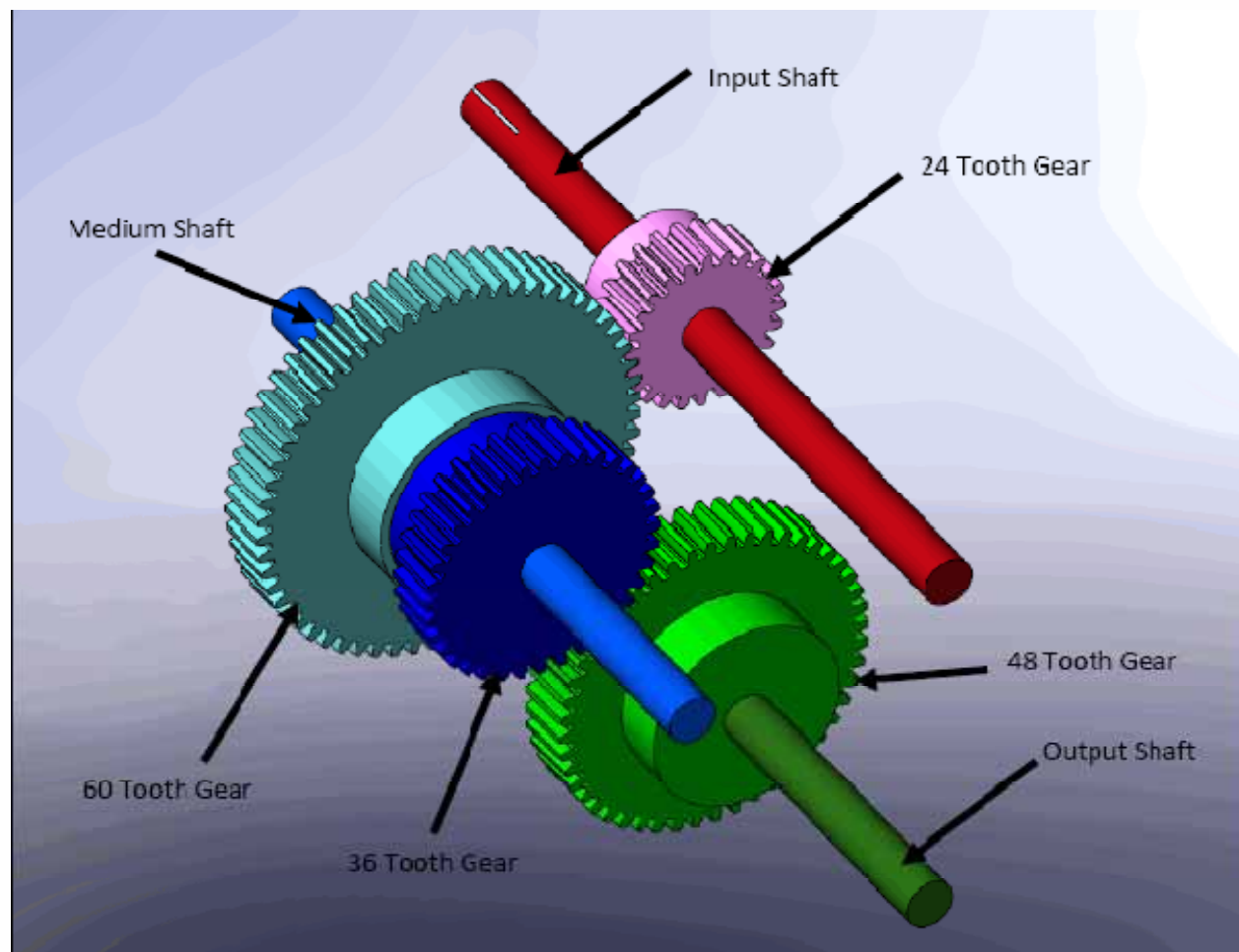

Planetary Gear Transmission I



Design Goal:

input power $P_1=22\text{kW}$;
input angular velocity;
 $n_1=1500\text{ rpm}$;
gear ratio: $i=99$;

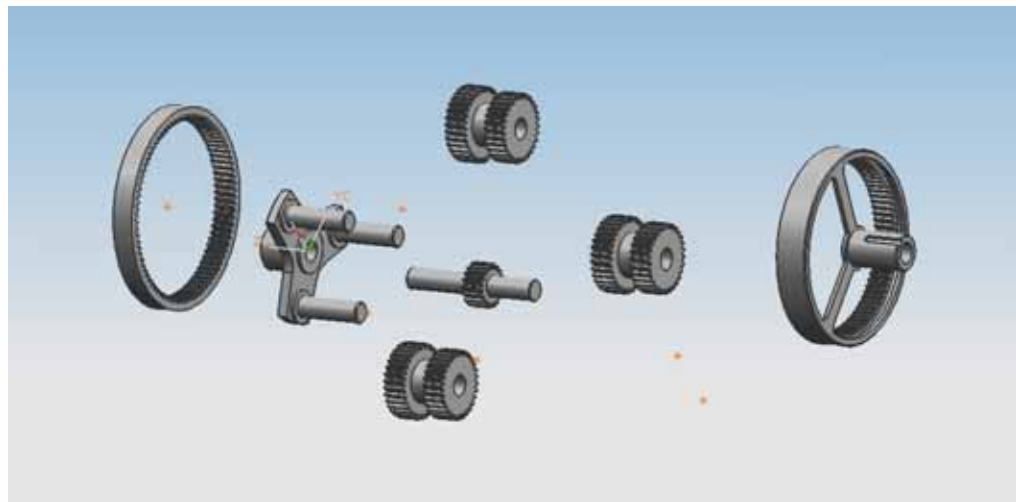
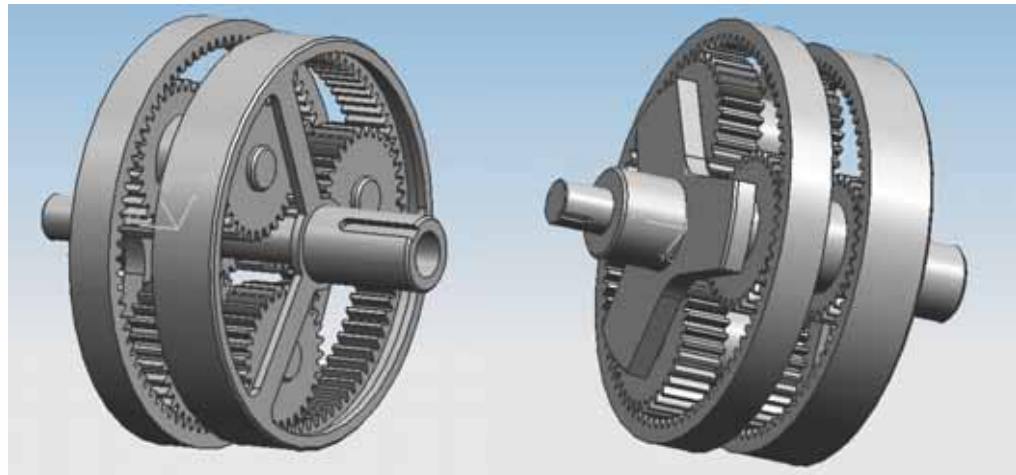

Differential Driving System

Design Requirement:

$P_1=7.5\text{kW}$; $n_1=980\text{ rpm}$
for motor 1;

$P_2=5.5\text{kW}$; $n_2=750\text{ rpm}$
for motor 2;

$z_1=28$, $z_2=98$, $z_a=20$,
 $z_c=37$, $z_b=94$;

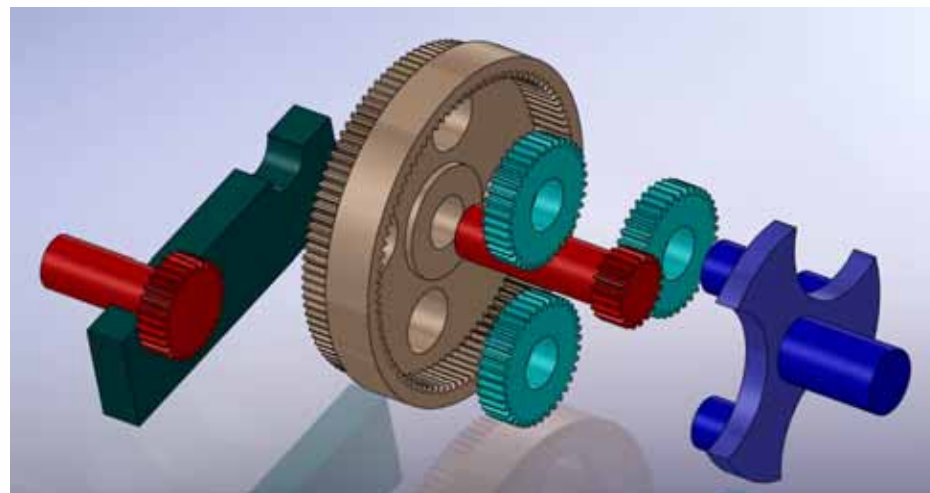
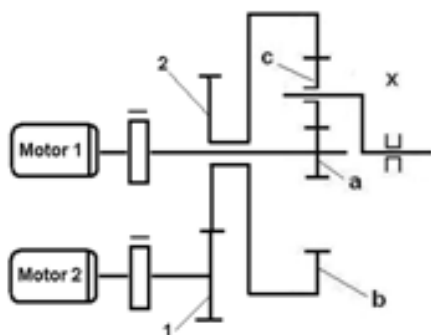
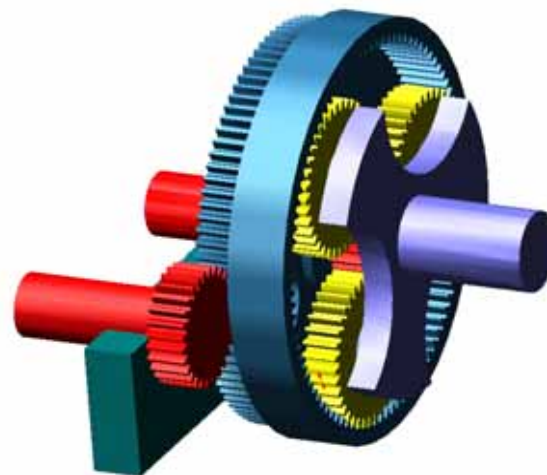

ADAMS Verification I

Case 1. Sun gear a operates at 180°/sec;
Theoretical carrier output is

$$n_x = \frac{n_1}{i_{ax}^b} = \frac{180}{5.7} = 31.57^\circ/\text{sec}$$

ADAMS carrier output:
31.52°/sec

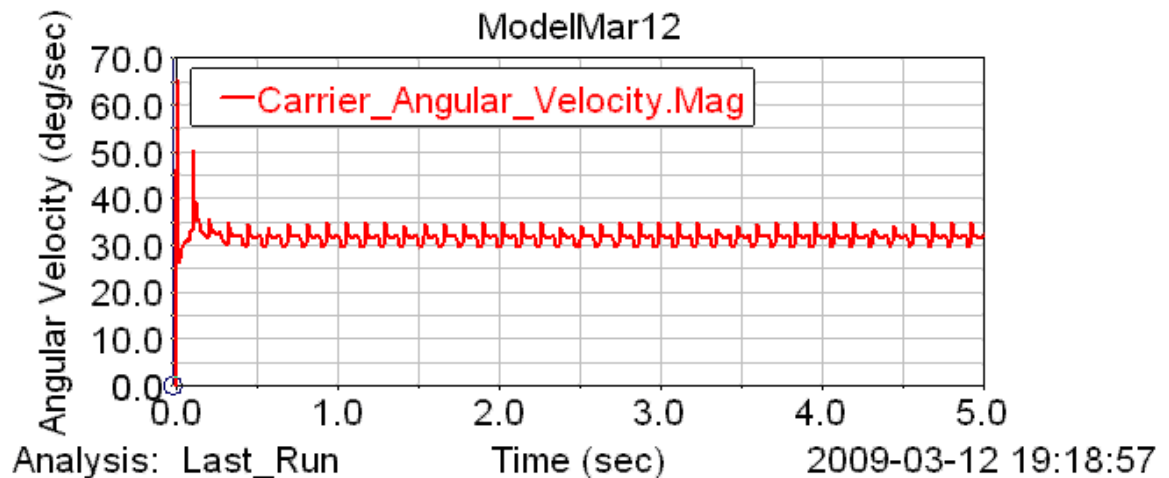
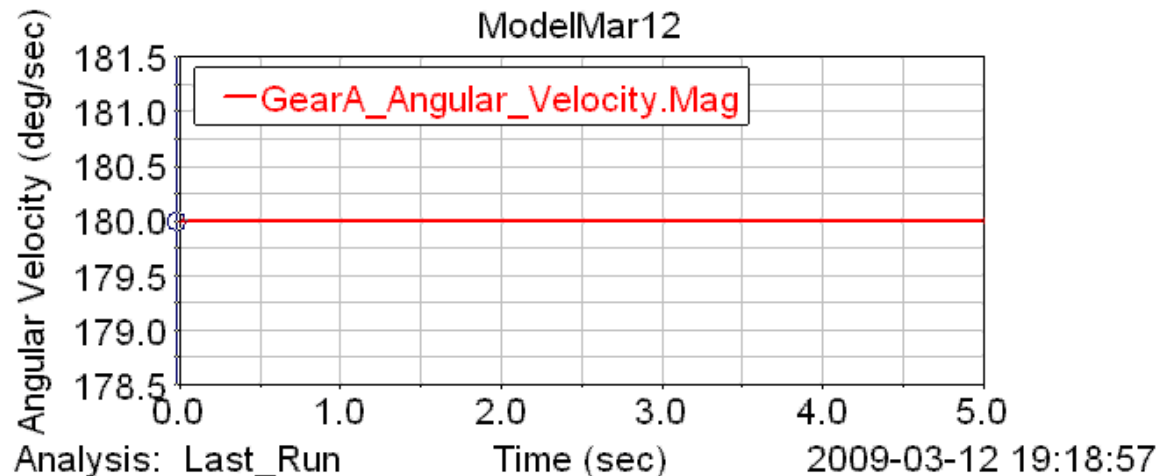

ADAMS Verification II

Case II. Sun gear a operates at 120°/sec; Gear 1 operates at 60°/sec; The motors run in opposite direction.

Theoretical carrier output is

$$n_x = \frac{n_a}{i_{ax}^b} + \frac{1}{i_{bx}^a} \frac{n_2}{i_1}$$

$$= \frac{120}{5.7} + \frac{60}{1.213 * 3.5} = 35.18^\circ/\text{sec}$$

ADAMS carrier output:
35.16°/sec

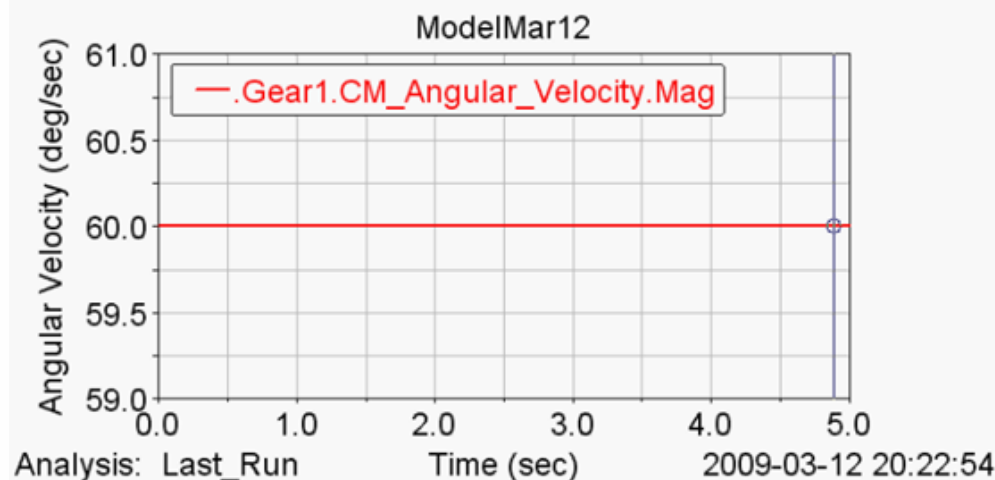
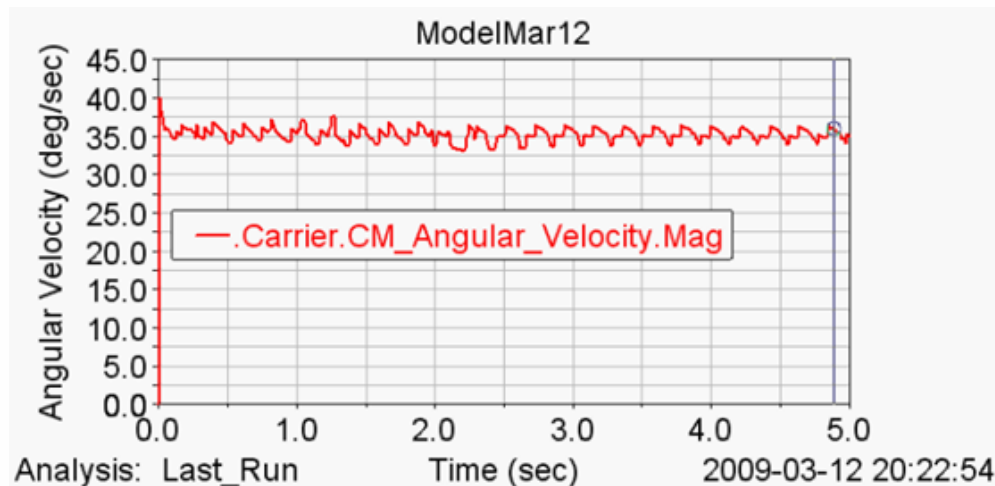

Planetary Gear Transmission II

Non-standard gear train design:

Design parameters: $P_1=22\text{kW}$; $n_1=1500\text{ rpm}$; Gear ratio: $i=134$

Number of sun gear teeth: 15; Number of planet gears: 3

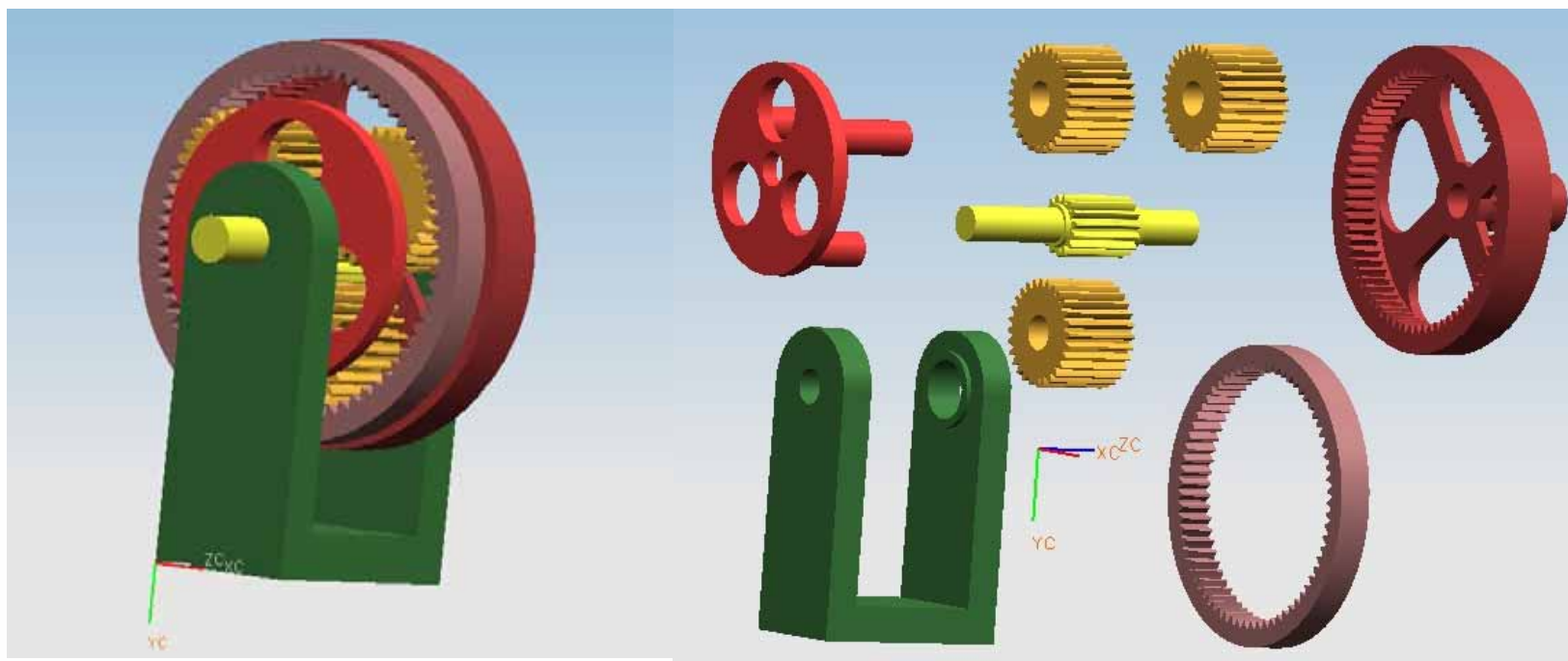

ADAMS Simulation Results

| <i>Known Frequencies</i> | <i>Hz</i> |
|--------------------------|-----------|
| <i>GMF</i> | 205.9 |
| <i>Input Shaft</i> | 16.71 |
| <i>Carrier</i> | 2.974 |
| <i>Planets</i> | 4.370 |
| <i>Output Shaft</i> | 0.1244 |

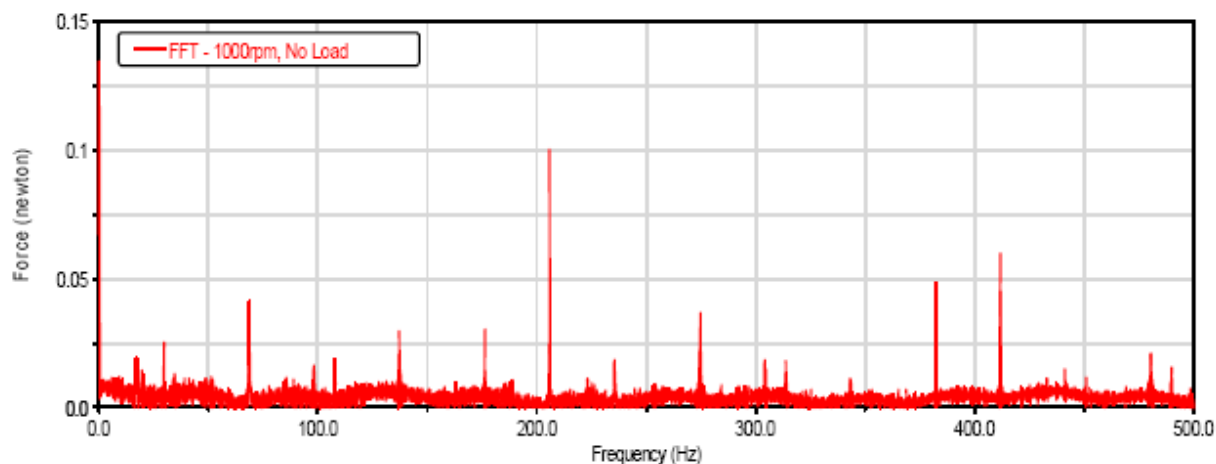

The FFT of the force on the input shaft joint yielded many peaks when the gearbox was very lightly loaded. Note: $29.4838 \text{ Hz} = \text{GMF}/7$; $274.5552 \text{ Hz} = 4\text{GMF}/3$; $411.8118 \text{ Hz} = 2\text{GMF}$, etc...

Conclusions and Acknowledgement

- ADAMS software can be used effectively to facilitate mechanical design with a short learning curve.
- ADAMS is being used to help our program meet ABET accreditation requirements for student skills.
- The introduction of ADAMS into the course allowed students to experience a culminating design experience that combined previous coursework.
- ADAMS can predict the fault patterns of a gear train and may obviate some costs of field testing.
- The authors have found the ADAMS software to be a useful teaching and research tool.
- The authors gratefully acknowledge the contributions from ME518 students.



Contact Details :

- For further information please contact

Xi Wu

Department of Mechanical Engineering
California Polytechnic State University
San Luis Obispo, CA93407-0358

Telephone Number: (805) 756-5214

Email Address: xwu@calpoly.edu